



CLASSIC TT & MANX GRAND PRIX

**SUPPLEMENTARY REGULATIONS**



# CONTENTS

	IMPORTANT INFORMATION	Page 2
1	ANNOUNCEMENT	Page 4
2	SECRETARY OF MEETING	Page 4
3	OFFICIALS	Page 4
4	COURSE	Page 5
5	RACE PROGRAMME	Page 5
6	ELIGIBILITY	Page 5
7	MGP ENTRIES AND ENTRY FEES	Page 6
8	INSURANCE/MACHINES RIDDEN ON PUBLIC HIGHWAY	Page 7
9	SIGNING-ON/BRIEFINGS	Page 7
10	TECHNICAL INSPECTIONS	Page 9
11	FLAG SIGNALS	Page 12
12	PRACTICE	Page 12
13	QUALIFICATION	Page 14
14	CHANGE OF NUMBER	Page 14
15	RACE PROCEDURE	Page 15
16	PROTESTS AND APPEALS	Page 17
17	WINNERS ENCLOSURE	Page 17
18	GARLANDING CEREMONY	Page 19
19	AWARDS	Page 19
20	TRANSPONDERS & AUTOMATIC TIMING	Page 19
21	ON BOARD CAMERAS & GPS	Page 19
22	MOBILE PHONES	Page 19
23	PADDOCK	Page 20
24	PERSONNEL PASSES	Page 22
25	VEHICLE RECOVERY SERVICE	Page 24
26	ACCEPTANCE OF RECORDS	Page 24
27	BREACH OF REGULATIONS	Page 24
28	INDEMNIFICATION OF CLUB	Page 24
29	JURISDICTION	Page 24
30	PUBLICITY	Page 24
31	MERCHANDISING	Page 24
32	MISCELLANEOUS	Page 25
33	USEFUL CONTACTS	Page 25
	APPENDIX A - Technical requirements for all race machines	Page 26
	APPENDIX B – Regulations specific to MGP race machines	Page 28
	APPENDIX C- Regulations specific to Classic TT race machines	Page 31
	SUMMARY OF TIMES	Page 37

## Important Information

### INSURANCE

Please note that these regulations are heavily revised for 2013 and all competitors, teams and entrants are encouraged to read them thoroughly before entering the 2013 Manx Grand Prix Races and/or Classic TT Races.

---

### CLOSING DATE FOR ENTRIES

Entries for the Classic TT Races close on Friday 3 May 2013.

Entries for Manx Grand Prix Races close on Saturday 8 June 2013.

---

### LICENCE REQUIREMENTS

ACU and SACU licence holders must have held as a minimum a National Licence issued by the ACU or SACU for at least six months prior to the first day of practising. Competitors from other FMN's must have held an FIM International Non - Championship Licence for a minimum of six months prior to the first day of practising.

In addition to enter this event all competitors must hold a "TT Course Licence" issued by the ACU at a cost of £25.00 in addition to any normal licence fees. An application form for such a licence may be downloaded from [www.manxgrandprix.org](http://www.manxgrandprix.org) should be returned to the Auto Cycle Union.

Please note - A "TT Course Licence" issued by the ACU does not guarantee an entry into the Manx Grand Prix Races.

Competition licences, starting permission (for non ACU/SACU licence holders) and TT Course licences must be produced when signing on.

---

### COMMENCEMENT OF PRACTICE

Riders with previous experience on the TT Course may apply for dispensation to the Clerk of the Course to commence practice no later than Wednesday 21 August. All newcomer riders must have commenced practice on Saturday 17 August and completed 3 laps before Wednesday 21 August.

---

### PERSONNEL PASSES

A number of significant revisions to the access granted by personnel passes in restricted areas in around the paddock and start line area and all competitors, teams and entrants are encouraged to make themselves familiar with these changes before the 2013 Manx Grand Prix Races and Classic TT.

---

### NUMBER BOARDS

Riders may use their own painted number boards but if they do so they must be matt and the RAL colours specified. Please note that some class number board colours have been changed for 2013. For more information see regulation 10.

---



## Important Information

### RIDING RACING MOTORCYCLES ON THE PUBLIC HIGHWAY

No motorcycle may be ridden on open roads, not even to and from the starting point at any time, without Road Traffic Act Insurance. This cover may be obtained from the Race Office.

Riders may wish to explore the possibilities of arranging cover through their own insurers for this purpose.

Third party insurance for all riders and personal accident insurance for ACU and SACU licence holders during the races and official practices are included in the Entry Fee. Non ACU and SACU licence holders must have Personal Accident insurance as required by their own national federation (see Reg. 8).

Insurance for increased benefits can be effected by application direct to:

#### Dawn Luby

Lockton International  
6th Floor  
19 Spring Gardens  
Manchester  
M2 1FB.

---

Tel: +44(0)161 828 3326  
Mobile: +44(0)7775574863  
Email: dawn.luby@uk.lockton.com

This insurance can also be obtained during signing on periods.

---

## CONTACTS

### *Main contact for Classic TT information:*

#### MMCC Office

The Grandstand,  
Glencrutchery Road,  
Douglas,  
Isle of Man,  
IM2 6DA.

---

Telephone : (01624) 644649  
Fax : (01624) 620174  
E-mail: mgp@manx.net  
www.manxgrandprix.org

#### Motorsport Team

Department of Economic Development  
St Georges Court  
Upper Church Street  
Douglas  
Isle of Man  
IMI IES

---

Telephone +44 (0)(1624) 686815  
E:mailto:info@iomtt.com  
Website:www.iomtt.com



## 2013 Manx Grand Prix Races and Classic TT Races Supplementary Regulations

### I. ANNOUNCEMENT

Manx Motor Cycle Club Limited, "MMCC" (a company incorporated in the Isle of Man (no 007491C)) whose registered office is situated at The Grandstand, Glencrutchery Road, Douglas, Isle of Man, IM2 6AD, ("the Club") will organise the Manx Grand Prix and Classic TT Races over the TT Mountain Course in the Isle of Man from 24 to 30 August. Official Practice will be from 17 to 23 August with additional practice on 24, 26 and 28 August. Permit No ACU 37405, FIM Inscription No IMN 191/58 and Temporary Course Certificate No TT001.

The MMCC is the owner of the logos, associated trademarks and designs of the Manx Grand Prix races and has agreed to grant to Department of Economic Development (DED) the use of same for the term of the existing contract between the parties. The DED (an Isle of Man Government Department), whose registered office is St Georges Court, Upper Church Street, Isle of Man, IM1 1EX, is the owner of the intellectual property rights logos, associated trademarks and designs of the Isle of Man TT Races, Classic TT Races and Isle of Man Festival of Motorcycling.

The status of the Meeting is an International. The Meeting will be held under the National Sporting Code and Standing Regulations for Road Racing of the ACU, these supplementary regulations and any further instructions issued or official announcements made ("The Regulations"). The Club may publish supplementary instructions on the official notice board in the Race Office at the rear of the Grandstand. Riders will be deemed to have received due notice of any instruction so published.

The regulations will not be altered, except as provided for in the National Sporting Code and may be interpreted only by the Stewards of the Meeting. Their decisions will be final except as provided in the National Sporting Code.

---

### 2. SECRETARY OF THE MEETING

Caroline Etherington,  
MMCC Office,  
The Grandstand,  
Glencrutchery Road,  
Douglas,  
Isle of Man,  
IM2 6DA.

Telephone : (01624) 644649  
E-mail: mgp@manx.net

---

### 3. OFFICIALS

ACU Steward:	TBA
ACU Centre Steward:	Edric Costain
Club Steward	Martin Moore
Classic TT Eligibility Officer	Mark George
Clerk of the Course:	Philip Taubman ACU 29276
Deputy Clerk of the Course/Operations:	Andrew Mackay
Deputy Clerk of the Course/Start/Finish:	Peter Cain
Chief Incident Officer:	Ned Bowers
Chief Medical Officer:	Dr Heike Romer
Chief Timekeeper:	Kevin Brookes
Chief Technical Officer:	Peter Maddocks
Deputy Chief Technical Officers:	Jeff Kirby/Joanne Rowe/Trevor Denning
ACU Sound Inspectors:	Mike Chapman/Sharon Hibberd
Engine Measurer:	Keith Spencer/Joanne Rowe/Trevor Denning
MGP Riders Liaison Officers:	John Barton/Carolynn Sells
Classic TT Rider Liaison Officers:	TBA

## 4. COURSE

The Meeting will be held on the 'Mountain' circuit which is 60.70km (37.73 miles) in length, on highway which is closed to the public during practice and race periods.

---

---

## 5. PROGRAMME OF RACES

### **Saturday 24 August – Classic TT Race Day 1**

---

1500hrs	Race 1	The 500cc Classic TT Race (4 laps)
---------	--------	------------------------------------

---

### **Monday 26 August – Classic TT Race Day 2**

---

10:15hrs	Race 2	The 350cc Classic TT Race (4 laps)
----------	--------	------------------------------------

---

---

10:15hrs	Race 3	The 250cc Classic TT Race (4 laps)
----------	--------	------------------------------------

---

*(Races 2 and 3 will run concurrently)*

---

13:00hrs	Race 4	The Formula 1 Classic TT Race (4 laps)
----------	--------	--

---

---

13:00hrs	Race 5	The Formula Classic TT Race (4 laps)
----------	--------	--------------------------------------

---

---

13:00hrs	Race 6	The Formula 2 Classic TT Race (4 laps)
----------	--------	--

---

*(Races 4, 5 and 6 will run concurrently)*

### **Wednesday 28 August – Manx Grand Prix Race Day 1**

---

10:15hrs	Race MGP1	The Newcomers Race A (4 laps)
----------	-----------	-------------------------------

---

---

10:15hrs	Race MGP2	The Newcomers Race B (4 laps)
----------	-----------	-------------------------------

---

---

10:15hrs	Race MGP3	The Newcomers Race C (4 laps)
----------	-----------	-------------------------------

---

*(Races 1, 2 and 3 will run concurrently)*

---

13:15hrs	Race MGP4	The Junior Manx Grand Prix Race (4 laps)
----------	-----------	--

---

### **Friday 30 August – Manx Grand Prix Race Day 2**

---

10:15hrs	Race MGP5	The SuperTwin Manx Grand Prix Race (4 laps)
----------	-----------	---

---

---

10:15hrs	Race MGP6	Lightweight Manx Grand Prix Race (4 laps)
----------	-----------	---

---

*(Races 5 and 6 will run concurrently)*

---

13:15hrs	Race MGP7	The Senior Manx Grand Prix Race (4 laps)
----------	-----------	--

---

## 6. ELIGIBILITY

### (a) Riders Licences

ACU and SACU licence holders must have held as a minimum a National Licence issued by the ACU or the SACU for at least six months prior to the first day of practising. Competitors from other FMN's must have held an FIM International Non - Championship Licence for a minimum of six months prior to the first day of practising.

In addition to enter this event all competitors must hold a "TT Mountain Course Licence" issued by the ACU at a cost of £25.00 in addition to any normal licence fees. An application form for such a licence may be downloaded from [www.manxgrandprix.org](http://www.manxgrandprix.org) and returned to the ACU.

In these regulations and in any other instructions or directive issued by the Club, the term "rider" shall refer to any person who has been accepted as a rider in any of the races.

Riders must be 18 years or older on 17 August 2013.

---

### (b) Additional conditions for classes

#### *Newcomers*

The only riders eligible for the Newcomers Race and the only riders regarded as newcomers in the Classic TT Races shall be those who have not previously qualified to ride or ridden in any motorcycle race run over the TT Mountain Course. A rider who has previously competed on the TT Mountain Course only as a TT sidecar driver or passenger will be regarded as a Newcomer. Riders entering the Newcomers Race may also enter for the Lightweight, SuperTwin or Senior Manx Grand Prix Races but may compete in these races only if they have qualified to start in the Newcomers Race or a Classic TT Race and achieved the qualifying time for the other races entered.

All Newcomers must practice with the Classic TT classes for the first 2 practice sessions and may only compete in one race per day.

#### *SuperTwin, Lightweight, Junior & Senior Manx Grand Prix*

See Appendix B

#### *Classic TT Races*

See Appendix C

---

### (c) Change of Rider

Only with the permission of the Clerk of the Course may a change of rider be allowed. Such permission will be granted only in exceptional cases and after investigation. A substitute rider may be nominated only by a licensed entrant. A change of both rider and make of motorcycle may be permitted at the discretion of the Clerk of the Course.

---

### (d) Medical Examinations

The Club may require any rider at his/her expense to undergo a medical examination by a doctor or by the medical board appointed by the Club and may disqualify a rider on medical advice. Every rider agrees to the results of any such medical examination being given to the Club.

A rider involved in an accident will not be allowed to continue practising or racing until he/she has been passed medically fit by one of the event Medical Officers.

---

### (e) Entrants

Entrants must be in possession of a valid National Entrants or FIM Sponsors Licence for Road Racing.

---

### (f) Machines

- MGP Races see Appendix B
  - Classic TT Races see Appendix C
- 
-

## 7. ENTRY PROCEDURE & ENTRY FEES

- MGP Races see Appendix B
- Classic TT Races see Appendix C

---

---

## 8. INSURANCE/MACHINES RIDDEN ON PUBLIC HIGHWAY

### (a) Insurance

The Organisers undertake to insure each rider; indemnifying him/her against any third party claims made arising out of the races or official practice, excluding claims by other riders, entrants, sponsors or mechanics.

Competitors who hold licences issued by the ACU or the SACU will be covered by Personal Accident insurance during official practice and racing, for the benefits detailed below. The cost of this Personal Accident insurance is included in the entry fee. Competitors holding licences issued by a FMN other than the ACU or SACU must submit a Starting Permission countersigned and stamped by the FMN which issued their licence.

*This must confirm that, during the meeting and the official practice, they are insured against the risk of personal accident in accordance with the FIM Sporting Code but with additional cover for Medical Treatment and Repatriation costs, as follows:*

- 25,000 Euros - Death
- 50,000 Euros - Temporary Partial Disablement
- 185,000 Euros - Medical Treatment
- 75,000 Euros - Repatriation costs

*Alternatively this cover may be purchased from the event Insurance Brokers in the Race Office at the Grandstand during signing on periods at the following rates:*

- MCUI - £85
- Other European Federations - £115
- Rest of the World - £165

*For ACU and SACU licence holders, the organisers will arrange personal accident cover for the following benefits:*

- £10,000 GBP Death or permanent total disablement
- £20,000 GBP Loss of, or loss of the use of, one or more limbs or eyes
- Competitors resident outside the United Kingdom should ensure they have sufficient private medical insurance to assist them on their return to their place of domicile for any on-going medical expenses incurred from injuries sustained whilst competing in the MGP Races.

*Increased insurance benefits can be arranged either in the Race Office at the Grandstand (during the MGP fortnight) or by application to:*

Dawn Luby, Lockton International, 6th Floor, 19 Spring Gardens, Manchester, M2 1FB.  
Tel: +44(0)161 828 3326, Mobile: +44(0)7775574863, Email: dawn.luby@uk.lockton.com

During the whole of the time the competing motorcycles are in the custody of the Club the motorcycles will be insured by the Club against damage by fire up to a maximum value of £25,000 per machine.

---

---

### (b) Machines on the Public Highway

- The law of the Isle of Man provides that racing machines shall not be ridden on the public highway, except being used on a journey:-
  - (i) between the place where it is kept and the start of the Course
  - (ii) between the place where it is kept and a point on the Course
  - (iii) from a point on the Course to the place where it is kept; or
  - (iv) between points on the Course

The above is applicable for a period of 3 hours before and 2 hours after a closure period provided that the motorcycle in question is competing in a practice or race during the closure period. During these times, third party insurance must be effective, for the person riding the machine. Any rider reported as having driven his/her motorcycle in such a manner as to constitute a nuisance to the public or in contravention of any law or statutory regulation may be disqualified or otherwise penalised. Third party insurance cover can be obtained from the Race Office. Machines used on the public roads outside these times must comply in every respect with Manx road traffic laws and race numbers must not be displayed.



## 9. SIGNING-ON/BRIEFING

### (a) Signing-on

All riders must sign-on at the Press Office, The Grandstand between the following times:

<i>Friday 16 August</i>	<i>13:00 – 16:00 (All riders including Newcomers)</i>
<i>Saturday 17 August</i>	<i>09:00 – 09:30 (Newcomers only followed by course instruction)</i>
	<i>09:30 – 11:00 (All other riders)</i>

- Competition licences, starting permission (for non ACU/SACU licence holders) and TT Course licences detailed in Reg 6 (a)(1), plus leathers, helmets (with visor), boots, gloves, transponders and identification disc MUST be produced personally for examination.
- Local addresses and telephone numbers must be supplied. Any notices posted in the Race Office or sent by the Club to riders at such addresses shall be deemed to have been served.
- All Race Office opening times will be displayed outside the Race Office.
- A declaration must be signed by riders, confirming that they have not sustained any injury or consulted with a doctor regarding any injury or illness since the issue of their licences.
- Each Newcomer will be required to wear a red waistcoat at all times during practice sessions. Waistcoats will be supplied by the Club during signing-on sessions. Replacements can be purchased at a cost of £10 each.

### (b) Newcomers' Course Instruction

- All Newcomers (irrespective of class) will be taken around the course by coach/minibuses on SATURDAY 17 AUGUST at 0930hrs with experienced instructors. This is compulsory and failure to attend may result in disqualification. All Newcomers (irrespective of class) to attend the Newcomers briefing upon their return to the Grandstand.

### (c) Riders Briefings

- All riders must attend a briefing prior to being permitted to commence practice. The briefings will take place in the Conference Suite adjacent to the Race Office at the following times:

<i>Friday 16 August</i>	<i>14:00</i>	<i>15:00</i>	<i>16:30</i>
<i>Saturday 17 August</i>	<i>11:15 (All riders except Newcomers)</i>	<i>12:00 (Newcomers Only)</i>	
<i>Monday 19 August</i>	<i>16:00</i>		

- All Newcomers must arrive, sign on, and take the Newcomers Course Instruction at 0930hrs and attend the Newcomers briefing at 1200hrs on Saturday 17 August or they may be disqualified.

### (d) Technical Briefings

- A technical briefing for competitors and one mechanic per competitor will be held on Saturday 17 August in the Conference Suite adjacent to the Race Office at the following times:-

*MGP riders at 13:15*

*Classic TT riders at 14:00*

- It is important that each rider is represented at this briefing.

### (e) Newcomers' Pre-Race Briefing

- Pre-race briefings will be held for Classic TT Newcomers on Saturday 24 August and MGP Newcomers on Tuesday 27 August, both at 1100hrs in the Pit Lane area if dry and Technical Inspections Bay if wet. These are compulsory.

### (f) MGP Newcomers' Pre-Race Briefing

- A briefing will be held on Thursday 29 August at 1100hrs (Newcomers A/B/C) in the Mike Hailwood Centre. This is compulsory.

## 10. TECHNICAL INSPECTIONS

### (a) Number plates

Self adhesive numbers and backgrounds must be supplied by the riders. Numbers must be legible and any numbers not meeting with the approval of the Chief Technical Official must be replaced. However riders may use painted backgrounds but if they do so they must be matt and the following colours must be used following the RAL colour table:-

Black	9005	Red	3020
Blue	5010	White	9010
Yellow	1003	Green	6002

Three numbers, placed and fixed as directed by the Club shall be displayed on the motorcycle during practice periods and races so as to be clearly visible to marshals from the front and both sides of the machine.

#### *The colours for practice and race number plates will be as follows:*

500cc Classic TT	Yellow plates with Black digits
350cc and 250cc Classic TT	Blue plates with White digits
Formula 1, Formula 2 and Formula Classic TT	White plates with Black digits
MGP Newcomers (A/B/C)	Red plates with White digits
Junior MGP	White plates with Blue digits
Lightweight and SuperTwin MGP	Green plates with White digits
Senior MGP	Yellow plates with Black digits

*Please also note: The practice plate colour will be the same as that used for the first race for that motorcycle, i.e. a 600cc machine entered in the Junior MGP (blue on white) and Senior MGP (black on yellow) will practice on blue plates.*

### (b) Pre Practice Technical Inspections

All machines bearing the correct number plates must pass through the Technical Inspections Bay for inspection/approval prior to practice, during the times listed. All riders must similarly pass through the Technical Inspections Bay with leathers, helmets, boots, gloves and identification discs prior to any practice. All helmets must have the official Technical Officers' sticker attached. Technical Inspections commence at the following times:-

Saturday 17 August	15:00 - 16:00 15:30 - 19:10 16:30 - 20:10	Newcomers incl Classic TT Newcomers Senior; Junior; SuperTwin (No Newcomers) Classic TT, Lightweight
Monday 19 August	16:00 - 19:00 17:15 - 20:00	Senior; Junior; SuperTwin (No Newcomers) Classic TT, Lightweight, All Newcomers
Tuesday 20 August	16:00 - 19:00 17:15 - 20:00	Classic TT, Lightweight, Newcomers B/C Senior; Junior; SuperTwin, Newcomers A
Wednesday 21 August	16:00 - 19:00 17:15 - 20:00	Senior; Junior; SuperTwin, Newcomers A Classic TT, Lightweight, Newcomers B/C
Thursday 22 August	16:00 - 19:00 17:15 - 20:00	Classic TT, Lightweight, Newcomers B/C Senior; Junior; SuperTwin, Newcomers A
Friday 23 August	16:00 - 19:00 17:15 - 20:00	Classic TT, Lightweight, Newcomers B/C Senior; Junior; SuperTwin, Newcomers A
Saturday 24 August	11:00 - 14:00	Newcomer A/B/C, Senior; Junior; SuperTwin, Lightweight
Monday 26 August	11:00 - 14:00	Newcomer A/B/C, Senior; Junior; SuperTwin, Lightweight
Wednesday 28 August	10:00 - 11:30	Senior; SuperTwin, Lightweight

**(c) Pre-Race Technical Inspections**

Motorcycles must be presented for pre race Technical Inspections at the Technical Inspections Bay on each race day for all riders racing on that day at the following times, which must be strictly adhered to.

Nos 61 upwards	08:00 - 08:30
Nos 31 - 60	08:30 - 09:00
Nos 01 - 30	09:00 - 09:30

*Any application for extension must be made during the times stated above*

- NB Riders need not necessarily present their motorcycles personally but must report personally wearing their protective clothing, helmets, visors, boots, gloves and identification discs not less than one hour before the scheduled start time of the race. Non compliance with this regulation renders the riders liable to disqualification.
- All competing motorcycles must be presented with stands and in all respects ready for the race. The Chief Technical Officer or his Deputy may exceptionally grant extensions to ensure that a machine is properly prepared.
- Motorcycles must, therefore, be presented for Technical Inspections, ready in all respects, for the start of the race, including fuel. The motorcycles will remain in the custody of the Club, after presentation, until 45 minutes before the start.
- For machine security only two persons, one with the machine and one with the stand, will be permitted into the parc ferme. They shall leave the holding area immediately after their motorcycles have been placed there after Technical Inspections and should note that except by leave of the Chief Technical Officer they cannot have access to their machines until 45 minutes before the start.

**(d) Post Race Examination**

- Every competing motorcycle must be placed in the finishing enclosure where it will be held for as long as may be required. Motorcycles must be collected immediately following an official announcement that they have been released, after which the Club disclaims any responsibility for motorcycles not collected. No responsibility is accepted for equipment at any time.
- Motorcycles may be examined at the end of the race by the Chief Technical Officer and may be sealed by the Chief Technical Officer for later examination. Every rider shall dismantle, or cause to be dismantled at his/her own expense such parts of his motorcycle as the Clerk of the Course may require for the purposes of such examination, at such time and place as the Chief Technical Officer shall require.
- No rider shall be deemed to have finished a race or to have set up or broken a lap record or to have accomplished the fastest lap in a race until his/her motor cycle has been examined if so required, and passed.

**(e) General**

- Helmets and visors, leathers, boots, gloves, identification discs and motorcycles must be produced personally by each rider for re examination if a rider falls off his/her machine or at any time if required by the Chief Technical Officer. Riders shall remove fairings from their machines if required by the Chief Technical Officer.

**(f) Change of Motorcycle**

- An entrant wishing to change the make or type of motorcycle, after entries have closed, must apply to the Race Office for approval by the Clerk of the Course, not later than 24 hours before the scheduled start time of the race. The rider must have qualified for the class of the machine to be raced and have completed 1 practice lap on the machine to be raced.
- No change of class will be permitted after Tuesday 20 August.
- NOTE: For the purpose of these regulations, make of machine will be determined by the make of the engine and the make of the engine must be declared at the time of registration.

**(g) Fuel**

Fuel for all practices and races must be one of the following and comply with the general specifications listed in Table 1. Furthermore, only the specified fuel type is permitted for use in classes or engine types as given in Table 2.

**Table 1. Fuel type general specifications:**

Property	Max Lead Mg/l	MAX RON	MAX MON	Oxygen% m/m	Benzene% v/v
Unleaded petrol	5	102	90	2.7	1.0
Leaded petrol	150	102	90	2.7	1.0
Avgas 100 LL	560	-	102	2.7	5.0

Values in this table are taken from the FIM/ACU regulations and are applied to the fuel types as indicated. For a full specification refer to the FIM regulations for fuel. Alternatives to Avgas 100LL are NOT permitted.

**Table 2. Motorcycle classes and engine types with permitted fuel for use:**

	250/350/500 Classic TT & Formula Classic TT	Any other 2 stroke	Up to 1000cc 4 strokes Inc. F1 & F2 Classic TT
Unleaded petrol	YES	YES	YES
Leaded petrol	YES	YES	NO
Avgas 100LL	YES	YES	NO

- Where a competitor is using other than Isle of Man sourced pump fuel he/she MUST provide a specification sheet for that fuel when requested by the Chief Technical Officer.
- These regulations strictly prohibit the use of 'Bluegas', power boosters, octane boosters and the like. No additions are allowed to the fuel with the exception of water or standard lubricants sold to the public. The responsibility for providing fuel for practice and races will be the competitor's. It is also the competitor's responsibility to ensure that his allocated filler, which will be provided, operates correctly. Any fuel left in fillers will be drained and removed, however it is the competitor's responsibility to check that his filler has been drained prior to adding his own fuel. The use of other quick filling equipment will not be allowed.
- The Steam Packet Company has stated that fuel may only be carried in the tanks of machines, cans/barrels will not be allowed. Spot checks will be carried out and anyone found in contravention of this ruling will not be permitted passage to the Island.
- In the practice or races, no fuel shall be carried on the motorcycle other than in the tank securely fitted to the motorcycle for the purpose.
- The Club reserves the right at any time before, during or immediately after practising or racing to take samples of the fuels used.
- During practice periods riders can only refuel in the holding area to the north side of the Technical Inspection Bays, engines must be stopped.
- Competitors must supply information at signing on regarding the quantity and location of fuel stored outside the Grandstand. This information will be supplied to the Isle of Man Fire Service.

**(h) Fuel Tanks/Capacities**

- In the interest of safety, the use of ready fuelled replacement tanks in the pit WILL NOT be permitted. Replacement tanks are permitted but must be empty and may only be filled when securely attached to the machine. Refuelling during the progress of any race must be carried out at the competitors designated pit. It is forbidden to open tank filler caps until the machine is stationary at its allotted pit and the engine is switched off. Penalty will be disqualification.
- **Each motorcycle must have only one fuel tank, which must not hold more than 24 litres.**
- **The use of temporary filling material to reduce the capacity of the tank is forbidden.**

## 11. FLAG SIGNALS

*The following flag signals may be used during practice or a race, and must be immediately obeyed:*

NATIONAL FLAG	Start
RED (waved)	Immediate stop, all riders. Pull in where safe. Await marshals' directions.
BLACK WITH ORANGE DISC	Displayed with rider's number - that rider to stop due to mechanical problems.
YELLOW (motionless)	Danger ahead, slow down, no overtaking.
YELLOW (waved)	Danger more imminent, slow down and be prepared to stop, no overtaking.
CHEQUERED	Individual finish

*The following advisory flag signals may be displayed:*

YELLOW AND RED STRIPED	Lack of adhesion
WHITE WITH BLACK "V"	Bad visibility warning.
WHITE WITH BLACK "SUN" or "S"	Sun dazzle.
WHITE FLAG WITH RED DIAGONAL CROSS	Wet or damp patches are affecting adhesion of a particular section of the Course
GREEN	Course clear.

---

---

## 12. PRACTICE

### **(a) General**

- Practice on the Course, which will be closed to the public, will be regulated and supervised by the Club and will be allowed ONLY from the 17 August at the times specified. The practice schedule may be altered by the Clerk of the Course due to circumstances or force majeure.
  - During any practice period, the Clerk of the Course or his deputy may decide to flag off riders between Governor's Bridge and the finishing line, in which case the foreshortened lap and the time recorded at the flagging off point will be counted towards qualification for the races.
  - The end of each practice session will be notified by the showing of yellow, chequered and red flags, as detailed at the riders briefing.
  - All riders will slow down and leave the course as directed, where a red flag is shown.
- 
-

**(b) Practice Periods**

Saturday 17 August	17:20 - 17:45	Newcomers incl Classic TT (speed controlled) (untimed)
	17:45 - 18:55	Senior; Junior; SuperTwin (No Newcomers) (untimed)
	19:00 - 20:10	Classic TT, Lightweight, All Newcomers (untimed)
<hr/>		
Monday 19 August	18:20 - 19:00	Senior; Junior; SuperTwin (No Newcomers)
	19:05 - 20:00	Classic TT, Lightweight, All Newcomers
<hr/>		
Tuesday 20 August	18:20 - 19:00	Classic TT, Lightweight, Newcomers B/C
	19:05 - 20:00	Senior; Junior; SuperTwin, Newcomers A
<hr/>		
Wednesday 21 August	18:20 - 19:00	Senior; Junior; SuperTwin, Newcomers A
	19:05 - 20:00	Classic TT Lightweight, Newcomers B/C
<hr/>		
Thursday 22 August	18:20 - 19:00	Classic TT, Lightweight, Newcomers B/C
	19:05 - 20:00	Senior; Junior; SuperTwin, Newcomers A
<hr/>		
Friday 23 August	18:20 - 19:00	Classic TT, Lightweight, Newcomers B/C
	19:05 - 20:00	Senior; Junior; SuperTwin, Newcomers A
<hr/>		
Saturday 24 August*	18:00 - 18:30	Newcomer A, Senior; Junior; SuperTwin
	18:35 - 19:00	Newcomers B/C & Lightweight
<hr/>		
Monday 26 August*	15:30 - 16:00	Newcomer A, Senior; Junior; SuperTwin
	16:05 - 16:30	Newcomers B/C & Lightweight
<hr/>		
Wednesday 28 August*	15:15 - 15:25	Senior; SuperTwin, Lightweight

*\*subject to race delays*

PLEASE NOTE

- Riders in the Classic TT Formula 1 and Formula 2 Races may be requested by the Clerk of the Course to practice with the modern machines.
- The above times are subject to alteration due to circumstances or force majeure.
- Motorcycles raced in the Junior MGP Race may not be used in the Wednesday 28 August practice session.
- Applications to practice out of session will not be considered unless in exceptional circumstances.

### **I3. QUALIFICATION**

- To start a race, a newcomer to the TT Course, qualifying for the first time must complete a total of at least 6 laps, including a speed-controlled lap. Newcomers in any class must have signed on, attended the Newcomers briefing and the Course Instruction on Saturday 17 August and commenced practice, including completion of a speed controlled lap and must have completed 3 laps on or before Wednesday 21 August, or they may be disqualified.
- Riders who have qualified to start in any previous race on the Mountain Circuit (TT or MGP) shall be required to have signed on and commenced practice on or before Wednesday 21 August to complete a total of at least 5 laps.
- A minimum of 2 laps (3 laps in the case of newcomers) must be completed on each machine entered, one of which must be within the qualifying time.
- In every case all qualifying laps must be completed on the motorcycle to be ridden in the race or on a machine of the class.

#### **Qualification times**

---

- MGP (All classes)	120% of the time set by the third fastest qualifier in the class
- Classic TT (All classes)	125% of the time set by the fastest qualifier in the sub class

---

- Unless otherwise decided by the Clerk of the Course the qualifying times will be based on the times set at the close of practice on Friday 23 August.
- All qualifying, including that on race days will be officially timed and count towards qualification. Qualifying must be at the sole discretion of the Clerk of the Course and there will be no right of Protest or Appeal.
- A rider, who is entered in more than one race on the same machine, may achieve a qualifying time during a race in order to compete in a subsequent race.

---

---

### **I4. CHANGE OF NUMBER**

- All competitors will be issued a riding number which will be listed in the official race guide and displayed on machines in the usual manner: Except for the Newcomers Race, the first 10 numbers in each class will be allocated by the organisers and subject to qualifying will start in numerical order at 10 second intervals. All other competitors will be allocated grid positions based on the best times recorded on completion of the Friday evening qualifying session. Riders qualifying after Friday may be permitted to start at the back of the grid, up to a maximum of 90 starters.
  - At the Technical Inspection prior to the race a small adhesive number will be applied to the front number plate to assist the start line personnel in arranging competitors in the correct starting order.
  - A list of grid positions will be available on [www.manxgrandprix.org](http://www.manxgrandprix.org) for MGP Races and on [www.iomtt.com](http://www.iomtt.com) for Classic TT Races and the official notice board in the Race Office. Race numbers will not be changed during the event.
  - The Clerk of the Course does however reserve the right to make a change of number when an application for a change of rider is approved or when other circumstances dictate that it is desirable to do so.
- 
-

## 15. RACE PROCEDURE

In exceptional circumstances, the start of any race may be officially delayed or a race may be reduced in number of laps or, if necessary, postponed until the following day or another designated day, abandoned or cancelled. Riders will be started at intervals of 10 seconds singly in each race or at such other intervals as the Club may determine.

### (a) Start Preliminaries

#### *First Signal - 45 minutes before start.*

Competitors take possession of machines in assembly area. Engines may be started for warm up period. Petrol and oil tanks may be topped up and adjustments made.

#### *Second Signal - 30 minutes before start.*

#### *Third Signal - 15 minutes before start*

Competitors marshalled to starting grid and lined up in order. Riders on the grid may at this stage make adjustments to the motorcycle or change tyres to suit the course conditions. Tyre warmers may be used on the grid, powered by a generator. Only one generator per machine may be used. The generator must be of the "hand carried" type and have a maximum output capacity of one kilowatt. The noise limit of the generator is 65 dB/A. No batteries or other electrical supplies are permitted on the grid except a self-contained starting device may be used. All adjustments and changes of tyres/wheels must be completed by the fourth signal.

#### *Fourth Signal - 5 minutes before start.*

Stand to, clear grid on the instructions of officials. Engines must be running. Exit gate from warm-up/assembly area to start line will close.

- 
- **Riders will not start until the starting flag is dropped.** Clutch or push starts will be permitted in all races.
  - Any rider who starts before the starting flag is dropped, or who fails to start immediately the starting flag is dropped may be penalised.
  - A rider who is not in position to start within 10 seconds of the scheduled starting time may only start 10 seconds after the last competitor is scheduled to start. The Clerk of the Course may adjust the starting time to coincide with the new starting position.
  - Only during the start procedure is a competitor permitted to stop on the course adjacent to his pit. At all other times a rider must use the pit access road and stop in front of his designated pit.
  - **Fire retardant overalls must be worn by all personnel at all times in the pit lane** after the 45 minute signal. Footwear worn by attendants must adequately protect the foot and not contain any studs, steel tips or anything likely to cause a spark.
- 

### (b) Pit Area and Pit Stops

#### (1) Pit Area

*The Pit Area is a Licensed Petroleum Storage Area under the Isle of Man Dangerous Goods Act and as such the following conditions apply:*

- There must be NO SMOKING or naked lights. Engines must be stopped whilst being refuelled. Any electrical equipment used or taken within 14ft of refuelling equipment must be either intrinsically safe or flame-proofed. This includes two-way radios, transistor radios, cellular telephones, cameras using electronic flash or motor drive and power tools. Spare batteries must be protected to prevent shorting across the terminals. Manx Radio earpieces are permitted. Please note that simply wrapping electrical equipment does not make it intrinsically safe and therefore no such equipment including electrically powered tools will be permitted in the pit area.
- Petrol cans used for filling and draining must be metal or BSI approved. Spare tanks in pits must be empty.
- Filling or refuelling of quick-fillers can be done only once the roads have closed and after the fire service have arrived. Fire retardant overalls must be worn when filling or refueling tanks.
- When quick-fillers are being filled or drained, only those persons immediately involved and race officials are permitted in the pit area.
- Quick-fillers must be drained when the pit lane is closed towards the end of the race. Any fuel not removed will become the property of the Club. Fire retardant overalls must be worn when draining fuel tanks.
- Unused fuel or empty drums which have contained fuel must not be carried beneath the Grandstand but may be taken across the pit lane only at the start line end.



## **(2) Attendants**

*Each rider is permitted up to three attendants. Passes are non transferable.*

*Riders must make their own arrangements for their supplies, including fuel, and for their pit attendants.*

*Every rider is responsible for ensuring that his pit attendants comply with official instructions and regulations and particularly the following rules:-*

- Only at his/her pit may the rider get assistance or replenishment. Giving instructions to riders by signal or by word of mouth will not be regarded as assistance within the meaning of this regulation.
- Only the rider's own attendants may assist him/her.
- Only when the machine is at or approaching the pit may the attendants get out of the pit to help the rider. They may not go beyond the safety line i.e. first line in front of pits.
- The attendants may make any adjustments, replacements or repairs and may replenish the motorcycle and hand out food or drink to the rider but must not use any parts, supplies or tools, other than spare wheels and tyres, except those previously lodged in his/her pit.
- One or two attendants may help the rider to restart.
- The use of purpose-made front wheel paddock stands designed to support unaided the front of the motorcycle during refuelling is permitted. The use of ramps or other means to elevate the front of motorcycles during refuelling is forbidden.
- Pit attendants are strictly forbidden to sit or stand on refuelling gantries.
- Pit Attendants must wear fire retardant overalls and suitable footwear at all times in the pit lane and warm up area after the 45 minute signal.
- Footwear worn by attendants must adequately protect the foot and not contain any studs, steel tips or anything likely to cause a spark.
- Crossing of the pit lane will be permitted only at the top end of the pit lane and the crossing point will be closed during pit stops. Equipment may not be removed from pits until the end of the race except under official supervision.
- One attendant must remain in the pit at all times to receive messages.
- Remote starters will be allowed in the pit lane but must not be operated until refuelling and servicing is complete.

## **(3) Pit Stops during races**

With the exception of a rider having difficulty at the start of a race only, all pit stops will be made in the pit lane between the pits and the Grandstand.

### **Pit lane speed limit - 60kph**

At the entrance to the Pit Lane is a Single White Line with a board at each side indicating a speed limit of 60 kph. From this point until the Pit Lane Exit which is indicated by a White Line with a board at each side with the 60kph crossed out, the speed limit is 60kph.

This speed limit will be policed by transponder loops in the Pit Lane.

*The following penalties will be issued to any competitor breaking the speed limit of 60kph and these penalties will be a matter of fact with no right of protest or appeal:-*

- Over 60kph but not over 80kph - time penalty of 30 seconds
- Over 80kph but not over 100kph - time penalty of 60 seconds
- Over 100 kph - disqualification from the race

In the event of more than one infringement during a single Pit Stop the highest penalty will be awarded.

At the entrance to the Pit Lane a display board will indicate the speed of competitors approaching the Pit Lane. This is only an indication to assist competitors.

The lifting of the front wheel of a motorcycle for the purpose of showmanship (whether in the pit lane or on the course and whether in practice or in a race) may be deemed to be dangerous riding and may result in disqualification.

---

## **(c) Finish of a race**

Riders who have completed the designated number of laps for the race will be shown a chequered flag by an official standing at the finish line. Riders crossing the finish line without completing the designated number of laps after the leading rider on the road has been shown the chequered flag may be permitted to proceed on a further lap. Where in the opinion of the Clerk of the Course it is no longer appropriate, he may order all competitors to stop as each crosses the finishing line. Riders not permitted to commence the final lap will be included in a partial classification established at the end of the penultimate lap of the race. Red lights will then be shown prior to the return road gate and a marshal showing a red flag will stand at the return road gate. The rider must be in contact with his/her machine.

**(d) Stopping a Race**

- A race will not be stopped prematurely unless the Clerk of the Course deems it necessary, but if so stopped before the leading competitor has completed half of the total race distance, the race will be declared abandoned. The finishing positions in an abandoned race will be ignored for the purpose of classification of the race result.
- A race stopped after the leading competitor has completed half of the scheduled race distance will be deemed to have been completed. The Clerk of the Course reserves the right to postpone or abandon any or all of the races if he considers it necessary.
- The Clerk of the Course may, notwithstanding the previous paragraphs, declare a result of any race based on such assessment as he thinks appropriate and, in doing so, may apply Section 10 of the ACU Standing Regulations for Road Racing to such extent (if any) as he thinks appropriate in the circumstances.
- In the event of the Clerk of the Course stopping a race prematurely due to 'force majeure' circumstances, waved red flags will be displayed at various points on the Course on the instructions of the Clerk of the Course or his Deputy. Stationary yellow flags will be displayed at intermediate marshals' posts. In the event of the Clerk of the Course shortening (as opposed to stopping) a race, this decision may be given to all riders at various points on the course. In these circumstances the chequered flag will be displayed at the start/finish line.

---

---

## 16. PROTESTS AND APPEALS

Protests against machine eligibility must be lodged on or before Friday 23 August. Protests must be in accordance with the ACU National Sporting Code Chapter 10, and accompanied by a fee of £100. In addition if the dismantling of an engine is involved, a deposit of £250 for 4 strokes and £150 for 2 strokes must be submitted with the Protest Fee as per ACU Road Race Regulation 14.23.3. In the event of the protest being upheld the Deposit will be returned. If the protest is unsuccessful the deposit will be awarded to the winning party and will be the only cost claimable. The time limit for making a protest will be 30 minutes after the display of the provisional results on the Official Notice Board in the Race Office. The deposit for a fuel test will be £600.

---

---

## 17. WINNERS ENCLOSURE

At the conclusion of each race the first three finishers will be directed into the Winners Enclosure with their machines to conduct interviews with the host television and radio broadcasters. No other television or radio journalists will be permitted to operate in this area. The Winners Enclosure will be separated into four distinct zones and certain passes will allow access to certain areas of the Enclosure. See full access list overleaf.

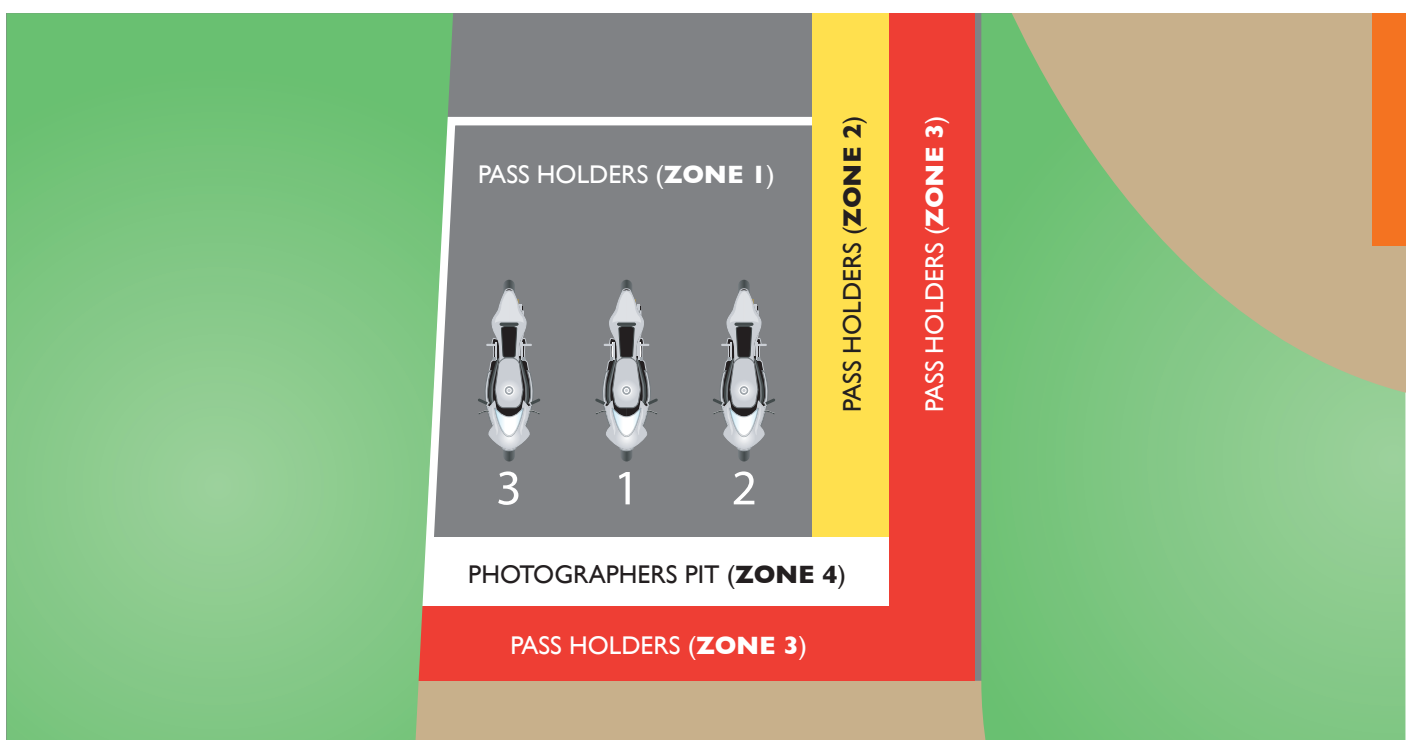

## 17. WINNERS ENCLOSURE (cont.)

The Winners Enclosure will be separated into four distinct zones and certain passes will allow access to the following areas:

### Zone 1

Zone 1 is the area the first three finishing machines will be parked immediately post race. Zone 1 can be accessed by the following passes only –

- Official Pass (Red)
  - Promoter Pass (Black)
  - Pit Team Pass (Yellow)
  - Host TV (Blue)
  - The host television and host radio personnel will also be permitted in this area under the supervision of the race organisers.
- 

### Zone 2

Zone 2 can be accessed by the following passes only –

- Official Pass (Red)
  - Promoter Pass (Black)
  - Pit Team Pass (Yellow)
  - Team Pass (Cyan)
  - Host TV (Blue)
  - TV (White)
- 

### Zone 3

Zone 3 can be accessed by the following passes only -

- Official Pass (Red)
  - Promoter Pass (Black)
  - Pit Team Pass (Yellow)
  - Team Pass (Cyan)
  - Platinum VIP Pass (Silver)
  - Host TV (Blue)
  - TV (White)
  - Photographer (Pink)
  - Media (Media)
- 

### Zone 4

Zone 4 can be accessed by the following passes only -

- Official Pass (Red)
  - Promoter Pass (Black)
  - Host TV (Blue)
  - TV (White)
  - Photographer (Pink)
- 

Outside of the main Enclosure will be two other areas. One will be clearly identified as a 'press pit' and will be for Gold and Silver Press Pass holders only. The remaining area will can be accessed by individuals with an Official Pass, Promoter Pass or Team Pass.

## **18. GARLANDING CEREMONY**

Riders finishing 1st, 2nd and 3rd in each race will be required to take part in a short ceremony to be held in front of the Grandstand to acclaim and garland the winners. This ceremony will take place approximately 10 minutes after the third placed competitor has entered the winners' enclosure.

---

---

## **19. AWARDS**

For details of MGP awards see Appendix B and for details of Classic TT awards see Appendix C.

AWARD PRESENTATIONS: Details of the dates and venue will be included in Final Instructions.

---

---

## **20. TRANSPONDERS AND AUTOMATIC TIMING**

- A separate transponder must be provided for each machine entered.
  - All practices and races will be officially timed using a transponder based automatic timing system.
  - It is the responsibility of each competitor to provide and properly fit a transponder; a fully charged AMB Tranx 260 or a directly compatible equivalent, at his/her own expense.
  - The identification number(s) of the transponder(s) must be the same as the identification number(s) on the entry form for that machine and class. No additional Transponder/lap recorder device is permitted on the machine during practice or races. Any change to transponder identification must be approved by the Clerk of the Course at least one hour before the start of practice or race. See also Appendix A.
- 
- 

## **21. ON-BOARD CAMERAS AND GLOBAL POSITIONING SYSTEMS**

- Only riders authorised by the Clerk of the Course will be permitted to film from on-board cameras, or to carry GPS on their machines.
  - Applications must be made on the official 'Application to the Clerk of the Course' form. Where such approval is granted, the installation of a camera or GPS and associated equipment is further subject to approval of the Chief Technical Officer.
- 
- 

## **22. MOBILE PHONES**

- The carrying and use of mobile phones in the Technical Inspections bays, the holding area and the pits is strictly forbidden unless the device is intrinsically safe.
- 
-

## 23. Paddock

The paddock will be organised by the promoter and its appointed agent G4S (Isle of Man) Ltd.

The Paddock Manager for G4S (Isle of Man) Ltd will be Lloyd Mister

Tel: 01624 649016, Fax: 01624 649049, Mobile: 07624 483945, E-mail: lloyd.mister@im.g4s.com

- Parking of all team vehicles will be under the control of the promoter and its appointed agent and all teams must respect the instructions received.
- Space will be allocated by the promoter and its appointed agent based on the information submitted by competitors in their entry application. The paddock parking position will be made by the promoter and its appointed agent and the decision will be final. Teams and / or competitors will receive notification of their paddock parking position on arrival.
- The Paddock will open at 9:00am TBC 2013.
- The Paddock will be segregated into various areas into which teams will be entitled to bring certain vehicles.
- The entire Paddock area is a closed road and access will only be granted by displaying an official event permit.

**IMPORTANT CHANGE FOR 2013 – Cars will not be permitted in any part of the paddock in 2013. All cars will be required to park in the official event car park situated in Nobles Park.**



### Retailing

Teams and competitors are not permitted to retail any goods or services from the paddock area during the TT period including merchandise. Any team or competitor wishing to retail in the specific paddock trade area should contact Motorsport Promotions Ltd on 01624667808.

### Containers

Containers will not be allowed in the paddock.

## **Scooters**

Scooters can be used for paddock transportation by riders and team personnel only (not children).

## **Health and Safety**

All competitors and their associated persons must at all times comply with all the health and safety requirements applicable in the paddock and displayed on the Race Office notice board.

## **Fuel Storage**

There will be a dedicated high octane fuel storage facility within the paddock. Teams and competitors using high octane fuel must contact the Paddock Manager for further information before sending any fuel to the Island. Teams and competitors using pump fuel are strongly advised to obtain fuel on the day it is to be used. Under no circumstance is more than 10 litres of fuel to be stored within any paddock (other than the official store). Teams and competitors who are storing fuels off site, are reminded of their obligations to let the authorities on the Isle of Man know what fuel is being stored and where. It is the responsibility of all teams and competitors to remove all metal fuel containers to the skips provided in the paddock. Any off site fuel storage facility (more than 2 litres) will need to be licensed by the Isle of Man Office of Fair Trading.

Please be aware that persons transporting large amounts of fuel **may face prosecution** if not appropriately licensed. Competitors should consider how and when fuel is obtained for each qualifying session and race. Competitors using pump fuel are reminded that they should purchase the amount needed for that session or race and that they should not store more than is needed.

## **Fire Extinguishers**

All competitors / race support / trade personnel using the paddock will need to supply a 2 Kg (minimum) dry powder fire extinguisher. The extinguisher must be visible at all times and have an in date certificate attached. Checks will be made during the event. All team members must be aware of its location and have knowledge in how it is operated.

## **Fire Points**

Fire points are located within Paddocks A, B, C and D and all team members must be familiar with their location. All Fire points are alarmed and extinguishers should not be removed unless needed in an emergency.

## **Welding**

The use of welding equipment within the paddock area is strictly forbidden. Under no circumstance should teams or competitors bring welding equipment in to the paddock or associated areas. Any equipment found may be confiscated.

## **Generators**

Generators must be placed in a safe working area. All cables used from generators or the electrical supply, must be covered by proprietary cable protector at all times. The use of generators should be kept to a minimum during night time hours.

## **Electrical Supply**

Under no circumstance should anyone interfere with the electric supply from the power masters in the paddock. If an electric supply fails, please contact the Paddock Manager in the first instance. Teams and competitors are required to have all electrical equipment PAT tested prior to use.

## **Security**

The paddock will be covered by security guards. There are two, 24 / 7 security points which are fixed. There will be a foot patrol during daylight hours but no foot patrols between 1900hrs and 0700hrs.

## **Rubbish Removal**

All competitors and team members are responsible for the removal of rubbish from parking and camping areas. Bins are provided for the disposal of bin bags located to the south of Paddock B.

## **Shower Block and Toilet areas**













Showers and Toilet areas will be cleaned between the hours of 0700hrs to 2100hrs. All areas will be checked and cleaned every hour.

## **General Notice**

A one way system will operate within the paddock. It has been designed for the smooth and safe transition of all vehicle movements. A 10 mph speed limit exists at all times. At no time should any vehicle block an entrance or exit.

## 24. PERSONNEL PASSES

There are different types of personnel passes depending on the activity of the pass holder providing access to various areas around the Start Line and Paddock.

 Competitor Wristband	 Guest Pass (Orange)
 Official Pass (Red)	 Event Support (Purple)
 Promoter Pass (Black)	 Host TV Pass (Blue)
 Pit Team Pass (Yellow)	 TV Pass (White)
 Team Pass (Cyan)	 Photographer Pass (Pink)
 VIP Guest Pass (Gold)	 Media Pass (Green)
 Platinum VIP Guest Pass (Silver)	

### Competitors Wristband

The competitors wristband is issued to all competitors and is to be worn by the competitor when requiring access to the Parc Ferme, Start Line and Grid prior to the commencement of practice or racing. This will replace the requirement for the competitor to be in possession of a Mountain Course License to gain access to these areas during these periods.

### Official Pass (Red)

The Official Pass is issued to the personnel who operate in roles on behalf of the race organisers and promoters and will require access to all areas. This pass will feature a passport size photograph of the pass holder. Anyone in possession of this pass is not permitted to use a camera in any of the pass holder areas.

### Promoter Pass (Black)

The Promoter Pass is issued to the personnel who operate in roles on behalf of the promoters and will have access to all areas. This pass will feature a passport size photograph of the pass holder. Anyone in possession of this pass is not permitted to use a camera in any of the pass holder areas.

### Pit Team Pass (Yellow)

The Pit Team Pass is issued to the personnel who work or do a professional activity during the event inside the restricted areas (Parc Ferme, Winners Enclosure (Zone 1), Start Line, Grid and including the Pit Lane).

Under no circumstances should Pit Team Passes be allocated or distributed to guests and any such passes will be withdrawn. Each solo rider and sidecar driver will be allocated a maximum of three Pit Team Passes. Additional Pit Team Passes may be allocated upon application to the Clerk of the Course.

Fire retardant overalls must be worn by all personnel in Pit Lane and this rule will be strictly enforced. Anyone involved in the refueling of machines in the Parc Ferme area must also wear fire retardant overalls. Footwear worn by Pit Team pass holders must adequately protect the foot and not contain any studs, steel tips or anything likely to cause a spark.

Anyone in possession of this pass is not permitted to use a camera in any of the pass holder areas.

### Team Pass (Cyan)

The Team Pass is issued to the personnel who work or carry out a professional activity during the event inside the restricted areas (Start Line, Grid, Winners Enclosure). This pass does not grant access to the Pit Lane or Parc Ferme. Under no circumstances should Team Passes be allocated or distributed to guests and any such passes will be withdrawn. Anyone in possession of this pass is not permitted to use a camera in any of the pass holder areas.

### VIP Guest Pass (Gold)

The VIP Guest Pass is issued by the promoters and provides access to the Official Classic TT Hospitality facility. Additional access to the Start Line will be granted by the promoter and such access will be marked on the pass. There will be four VIP Guest Passes, one for each race day, and will only be valid for the race day identified on the pass. This pass does not allow access to the Parc Ferme, Winners Enclosure, Grid or Pit Lane.

### Platinum VIP Guest Pass (Silver)

The Platinum VIP Guest Pass is issued by the promoters and provides access to the Official Classic TT Hospitality facility, Parc Ferme, Winners Enclosure (Zone 2), Start Line and Grid. There will be four Platinum VIP Guest Passes, one for each race day, and will only be valid for the race day identified on the pass. Holders of these passes will be accompanied by a representative of the promoter at all times when inside the restricted areas.

### **Guest Pass (Orange)**

The Guest Pass is issued by the organisers and/or promoters and provides access to the Start Line and Grid (practice periods only). This pass does not grant access to the Pit Lane or Parc Ferme.

### **Event Support Pass (Purple)**

The Event Pass is issued to the personnel who work or carry out a professional activity during the event inside the restricted areas who are not race officials. This pass will have access to all areas. This includes but is not restricted to personnel carrying out maintenance contractor work, cleaning and hospitality.

### **Host TV Pass (Blue)**

The Host TV Pass is issued to personnel who work for a TV production company employed by the organiser and/or promoter. The Host TV pass will have access to all areas and pass holders will also be required to wear a blue Host TV tabard.

### **TV Pass (White)**

The TV pass is issued to personnel working for independent TV production companies and TV news organisations who may need to work inside the restricted areas (Start Line, Grid, Winners Enclosure). This pass does not grant access to the Pit Lane or Parc Ferme.

### **Photographer Pass (Pink)**

The Photographer pass is issued to photographers accredited by the Chief Press Officer who may need to work inside the restricted areas (Start Line, Grid, Winners Enclosure). This pass does not grant access to the Pit Lane or Parc Ferme.

### **Media Pass (Green)**

The Media pass is issued to journalists accredited by the Chief Press Officer who may need to work inside the restricted areas (Start Line, Grid, Winners Enclosure). This pass does not grant access to the Pit Lane or Parc Ferme.

### **Pass General Rules**

- Teams and competitors are responsible for the integrity of the pass system within their team. Sanctions will be imposed on any team whose members abuse the pass system in any way including:
    - Selling passes
    - Production, sale or distribution of forged passes
  - Teams and competitors are also responsible for the behaviour of their guests. Guests should be advised that they are expected to respect the instructions of race officials.
  - By accepting the issue of passes for the Event, the team and / or competitor are deemed to agree to abide by the pass conditions and to undertake the obligation to advise each person to whom a pass is issued of the pass conditions and to ensure the observance thereof.
  - Passes may only be used to gain access to the areas indicated on the face of it. Any person found within a restricted area without the appropriate pass may be removed from the venue immediately and / or have any pass held by them withdrawn.
  - Passes must not be removed from their official lanyards and must be worn around the neck of the person to whom it is issued so as to remain clearly visible at all times.
  - The organisers at all times reserves the right to refuse admission to the venue or access to a designated area to any person, notwithstanding that such person may have been issued with an appropriate pass.
  - Teams and competitors must keep accurate records of the numbers of passes that they issue to guests, this information must be available for audit by the organisers at an event.
  - The organisers reserve the right to request further proof of identity in addition to a pass. Passes at all times remain the property of the organisers and may be issued, altered or withdrawn at any time at the absolute discretion of the organisers.
- 
-



## **25. VEHICLE RECOVERY SERVICE**

A recovery service will operate throughout the practices and races. Any machines collected will be returned to the Technical Inspections Bay. The organisers do not accept any responsibility for any damage to any machine. Security is the responsibility of the competitor who must ensure that they or an attendant remains with the machine until collected.

---

---

## **26. ACCEPTANCE OF RECORDS**

Entrants and riders must accept the official records of the Club which may be published as the Club thinks fit and also agree not to publish or allow to be published, on their behalf, any inaccurate, misleading or premature advertisement in connection with these races.

---

---

## **27. BREACH OF REGULATIONS**

The Clerk of the Course is empowered to impose penalties of a reprimand and/or fine, or disqualification, for breach of these regulations where no other penalty is specified. Any rider not complying with instructions of an official of the meeting (including security personnel employed by the promoter) may be penalised.

---

---

## **28. INDEMNIFICATION OF THE CLUB**

It is one of the conditions upon which entries are accepted for these races that the Club will not be responsible for any damage that may be done to any competing motorcycle or to its accessories during the meeting, either by fire, accident or otherwise, nor for the theft of the motorcycle or any of its accessories except as provided by Regulation 8.

---

---

## **29. JURISDICTION**

Each entry, if accepted, will form a contract between the Club and the entrant/rider, which will be governed by and construed in all respects in accordance with Isle of Man Law. Each of the parties irrevocably submits to the jurisdiction of the Isle of Man Courts in respect of any legal action or proceedings arising out of the contract or the participation of the entrant/rider in the meeting.

---

---

## **30. PUBLICITY**

Each competitor, as requested, must make themselves available free of any charge or expenses to the Promoter during the event for promotional purposes. Riders finishing first, second and third in each race shall attend the podium ceremony. In submitting an entry each competitor and entrant agree that the promoter and the event sponsors may make use of his/her activities and successes in motorcycle sport for any advertising, publicity, public relations and merchandising purposes. All riders may be required to carry an event and/or sponsors logo.

---

---

## **31. MERCHANDISING**

The competitor and entrant will authorise the Promoter to use and reuse and licence the use of images and representations of the competitor and team motorcycles competing in the event (including the manufacturer's name and logo), and the name, images and representations of the competitor and team paraphernalia including (in so far as the same appears on the clothing worn by the competitor or on team paraphernalia or on the motorcycles participating in the event) the logo and decals of all sponsors of the competitor and/or team for the purpose of producing merchandise exploiting the reputation of the event.

The competitor and entrant acknowledge and agree that the Promoter and those authorised by it have the exclusive right to produce or authorise the production of interactive games of the event and games including individual elements of the event.

The competitor, entrant and/or team authorise the Promoter to use and licence others to use all event images and other material relating to the event in marketing and packaging material and commercial advertisements exploiting the event or merchandise of the event or any individual elements of the event.

The competitor and entrant shall assist the Promoter and those authorised by it with the promotion of the event and production and promotion of merchandise associated with the event.

## 32. MISCELLANEOUS

Riders, sponsors, manufacturers, entrants, and team personnel may not either individually or with any such participants or through any representative or agent, procure, solicit or arrange for any supplies, gratuities, products, merchandise, equipment or any other thing of value to be provided from any source whatsoever bearing or depicting the official Isle of Man Festival of Motorcycling logo(s) and/or any trademark and/or any copyright and/or image used or associated with the event without the prior written permission of the Promoter to do so.

All the broadcast, recording, terrestrial, cable, satellite, digital, video and rights in all other media (including but not limited to WAP or similar mobile communications platforms and/or devices, Internet, Interactive and/or other competitor accessed sources) to the Manx Grand Prix races are owned by the MMCC and are the subject of a licence granted by the MMCC to the promoter.

All the broadcast, recording, terrestrial, cable, satellite, digital, video and rights in all other media (including but not limited to WAP or similar mobile communications platforms and/or devices, Internet, Interactive and/or other competitor accessed sources) to the Classic TT Races are owned by the DED.

Any recording, broadcast, rebroadcast or reproduction without express permission of the Promoter is strictly prohibited. Competitors, entrants, sponsors or manufacturers currently registered in the event may, subject to the prior written permission of the Promoter and subject to any conditions that they may impose at their absolute discretion, be granted rights to use broadcast material for their own specific promotional use within the British Isles without fee or charge except any that may be levied for technical and or research purposes. Rights requested by sponsors, advertisers, or any other commercial use must be made in writing to the Promoter and will be subject to Licence, which may include a fee or charge.

---

## 33. USEFUL CONTACTS

### ***Motorsports Team (Isle of Man Tourism)***

Department of Economic Development  
Upper Church Street  
Douglas  
Isle of Man, IM1 2PX  
Tel: +44 (0) 1624 686802  
Fax: +44 (0) 1624 686800  
E-mail: [iomtt@gov.im](mailto:iomtt@gov.im)

### ***IOM Vintage Motor Cycle Club***

The Old Vicarage  
Main Road  
Kirk Michael  
Isle of Man  
Tel: +44 (0) 1624 878242  
Email: [tonyeast@manx.net](mailto:tonyeast@manx.net)

### ***Isle of Man Steam Packet Co Ltd***

P O Box 5  
Douglas  
Isle of Man  
Tel: +44 (0) 1624 661661  
Fax: +44 (0) 1624 645608  
E-mail: [res@steam-packet.com](mailto:res@steam-packet.com)

### ***Isle of Man MGP Press Office***

The Grandstand  
Glencrutchery Road, Douglas  
Isle of Man  
Tel: +44 (0) 1624 644622  
Fax: +44 (0) 1624 644642  
E Mail : [mgp@manx.net](mailto:mgp@manx.net)

### ***Doodson Broking Group***

Lockton International  
6th Floor, 19 Spring Gardens  
Manchester, M2 1FB  
Contact: Dawn Luby  
Tel: +44 (0) 161 828 3326  
Mobile: +44 (0) 7775-574863  
Email: [dawn.luby@uk.lockton.com](mailto:dawn.luby@uk.lockton.com)

### ***ACU***

ACU Road Race Department,  
ACU House  
Wood Street  
Rugby, CV21 2YX  
Tel: +44 (0) 1788 566400  
Fax: +44 (0) 1788 573585  
E-mail: [rr@acu.org.uk](mailto:rr@acu.org.uk)  
[www.acu.org.uk](http://www.acu.org.uk)

### ***Trading Standards Division (Isle of Man)***

Office of Fair Trading  
Lord St, Douglas  
Isle of Man  
Tel: + 44 (0) 1624 686520  
Fax: + 44 (0) 1624 686504

### ***Transponders available from:***

AMB it  
Zuiderhoutlaan 4  
2012 PJ Haarlem  
The Netherlands  
[www.amb-it.com](http://www.amb-it.com)

## APPENDIX A - APPLICABLE TO ALL MACHINES

### 1 TYRES

Owing to variations in weather conditions which can occur on the TT Course and in the interests of safety, only tyres having a moulded tread pattern will be permitted. No additional cutting of moulded tyres will be permitted. No slicks, cut or uncut, will be allowed. Metal valve caps (not extractor type) must be fitted. Valves must be of the short stub stem type.

### 2 OIL FILTERS

All spin-off oil filters must be jubilee clipped and wire locked.

### 3 WHEEL NUTS & SPINDLES

All wheel nuts and spindles must be wire locked. Where this is impractical, fork leg retaining/pinch bolts should be wired.

### 4 BRAKES

- i) **Brake Lines:** For machines fitted with two front disc brakes, the split of the front brake lines for both front calipers must be made at or above the lower fork.
- ii) **Brake Calipers:** Where the brake pad pin is retained by one fastener, a secondary fixing is required.

### 5 PREPARATION

Must be in accordance with the ACU Standing Regulations and these Supplementary Regulations. The Club reserves the right to refuse any entry or to forbid the use of any particular machine which the Club considers inappropriate for racing on the TT course, or otherwise not to be in the spirit of this event. All machines must be prepared to a high standard of cosmetic appearance. Untidy machines will not be permitted to start in any event.

### 6 COOLANTS

No liquid engine coolants, other than lubricating oil or water should be used. This is because oil based substances can be dangerous if spilt on the road.

### 7 BORE & STROKE

Bore and stroke must be clearly marked on the motorcycle.

### 8 EXHAUST SPRINGS

All exhaust springs including those to the cylinder head must also be held by wire to ensure that the springs remain on the machine in the event of spring failure.

### 9 OIL CONTAINMENT

In the interests of safety Standing Regulations will be enforced.

### 10 CHAIN GUARDS

A chain guard must be fitted in such a way as to cover the point where the chain runs onto the rear sprocket and irrespective of wherever the rear wheel is positioned to maintain correct chain tension. The guard must be made of substantial material and must be securely mounted to the swinging arm so that it cannot rotate and come into contact with the chain or sprocket.

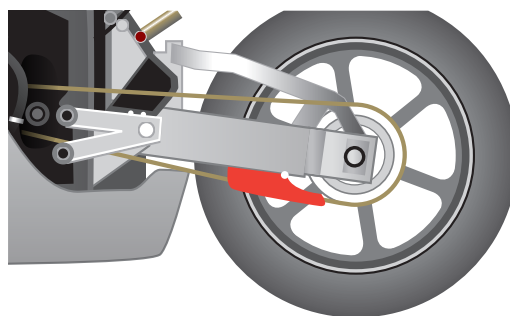

### 11 MONZA FILLER CAPS

All Monza filler caps must be fitted with an "R" clip or other device, to prevent unintentional opening of the cap. The device must be replaced after any pit stop.

## 12. TRANSPONDERS

- Ensure that the transponder holder is fitted securely, preferably using bolts and Nylock nuts (if tie-wraps are used at least two sufficiently strong tie wraps are needed to secure the holder).
- The transponder must be mounted VERTICALLY and NOT horizontally.
- The securing pin must be at the top.
- Fit the transponder holder in a safe and secure position.
- Mount the transponder so that it is preferably no more than 2 ft (60 cm) from the ground.
- Mount the transponder so that it is away from heat generating bodies such as the exhaust.
- Mount the transponder so that it has as clear a view of the ground as possible. Note – the transponder signal will not pass through metal or carbon fibre based plastics.
- Push the 'R' clip right through as far as possible in order to prevent it being accidentally pushed out.
- The transponder must be fitted whenever your machine is taken into the assembly area and whenever it is on the course, including timed and untimed practice sessions.
- The transponder must be charged and 'flashing' green and fitted to the machine when presented for Technical Inspections.

**Disregarding any of the above guidelines may result in your time(s) not being recorded.**

*No time will be recorded at all if the transponder is not fitted or has not been charged.*

### PREFERRED POSITIONS:

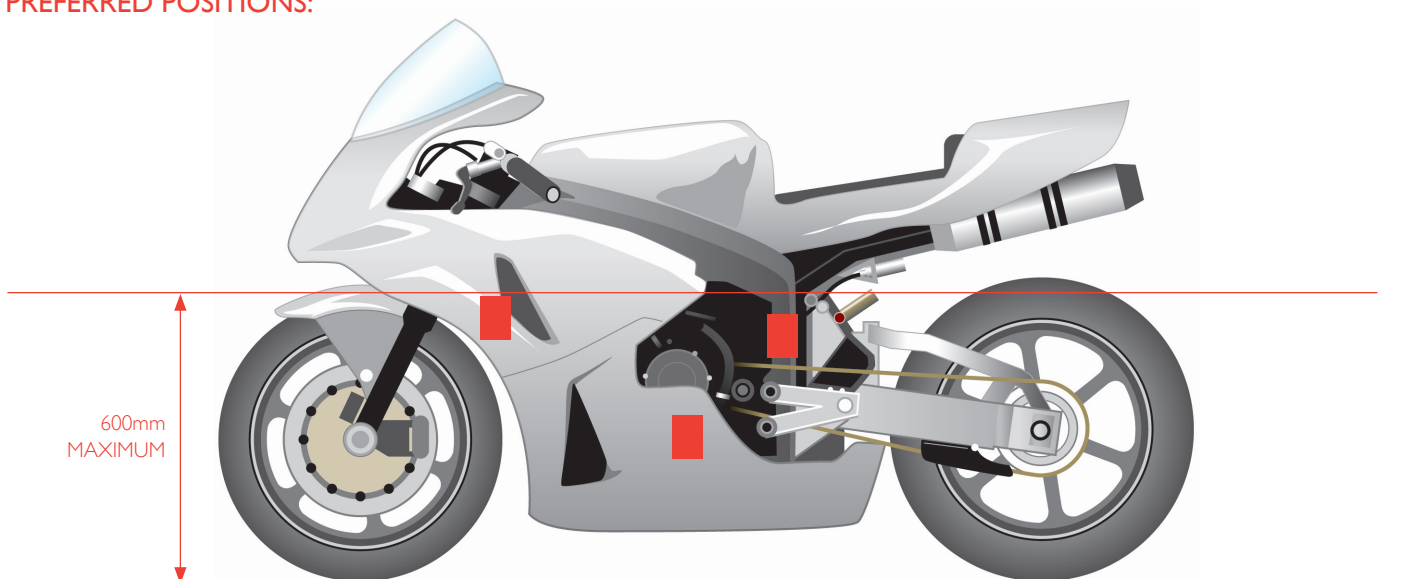

## APPENDIX B - APPLICABLE TO MANX GRAND PRIX MACHINES ONLY

### I. MACHINE ELIGIBILITY

#### (a) Riders (*SuperTwin, Lightweight, Junior & Senior Manx Grand Prix*)

- (i) Previous winners of Newcomers, Lightweight, SuperTwin, Junior and Senior Manx Grand Prix Races will be Considered subject to (ii) below:-
- (ii) Riders who have previously competed in any TT solo race on the TT Mountain Course are NOT eligible if:-
- they have qualified to start in any TT solo race on the TT Mountain Course in the last two years, eg a rider who wishes to compete in the 2013 Manx Grand Prix must not have qualified to start in any TT solo race on the TT Mountain Course in 2012 and 2013.
  - they have won a silver replica in any TT solo race on the TT Mountain Course in the last four years, eg a rider who wishes to compete in the 2013 Manx Grand Prix must not have won a silver replica in any TT solo race on the TT Mountain Course from 2010-2013 inclusive.

Note – Should a rider be in doubt as to the status of any event he/she may have entered he/she should contact the Secretary of the Meeting.

#### (b) Machines

##### NEWCOMERS RACE in 3 classes

###### Class A

550cc – 750cc	4 stroke 4 cylinder
651cc – 1000cc	4 stroke 2 cylinder
601cc – 675cc	4 stroke 3 cylinder
501cc – 1000cc	rotary equivalent

###### Class B

201cc – 450cc	2 stroke 2 cylinder
Up to 650cc	4 stroke 2 cylinder

###### Class C

Up to 125 cc	2 stroke single cylinder; 6 gears maximum
251cc – 400cc	4 stroke, 4 cylinder. Rebores to a maximum increase of +1.00mm above the standard bore size are permitted.
Up to 450cc	4 stroke single cylinder

---

##### JUNIOR MANX GRAND PRIX RACE

201cc – 250cc	2 stroke 2 cylinder
550cc – 600cc	4 stroke 4 cylinder
601cc – 675cc	4 stroke 3 cylinder
651cc – 750cc	4 stroke 2 cylinder

---

##### SUPERTWIN/LIGHTWEIGHT MANX GRAND PRIX RACE in 2 capacity classes

###### Class A SuperTwin

201cc – 450cc	2 stroke 2 cylinder
Up to 650cc	4 stroke 2 cylinder

###### Class B Lightweight

Up to 125 cc	2 stroke single cylinder; 6 gears maximum
251cc – 400cc	4 stroke 4 cylinder. Rebores to a maximum increase of +1.00mm above the standard bore size are permitted
Up to 450cc	4 stroke single cylinder

---

##### SENIOR MANX GRAND PRIX RACE

550cc – 750cc	2/4 stroke 4 cylinder
651cc – 1000cc	4 stroke 2 cylinder
601cc – 675cc	4 stroke 3 cylinder
501cc – 1000cc	rotary equivalent

If insufficient entries are received for any class, the Club may at its discretion amalgamate that class with any other class, and/or offer entrants the opportunity to transfer to another class and change their machines to one eligible for the other class.

## 2. ENTRY FEES AND PROCEDURE

- (a) MGP Entries may only be made online via the Manx Motor Cycle Club website [www.manxgrandprix.org](http://www.manxgrandprix.org) by Saturday 8 June with the appropriate insurance contribution (see below). See Reg 8 for non ACU & SACU Licence Holders.

<b>ACU/SACU</b>	<b>Non ACU/SACU</b>
£333 per race	£ 231 per race

- The insurance contribution for non ACU/SACU riders will be £231 as the cost of their personal accident insurance will not be paid by the Club.
- An administration fee of £25 will be payable for entries received after Friday 26 April after 5.00 pm.. Newcomers will be exempt from this surcharge.
- The Club reserves the right to refuse any entry and abandon, cancel or postpone the meeting or alter the programme of events and awards.
- Unless, in the opinion of the Club, sufficient entries are received for a race, that race will not be held, in which case entry fees will be returned. The entry fee may be returned in full if an entry is refused, but there is no other right to a refund and any given will be at the discretion of the organisers.
- For each race a maximum of 100 entries will be accepted, from which 90 will be permitted to race, starting singly at 10 second intervals.
- Priority will be given to Manx Grand Prix Replica winners in the last two years.
- The remaining entries will be allotted at the Club's discretion.
- Riders may apply for entries in more than one race.
- Riders (except all Newcomers) may apply to enter two races run on the same day provided they do not use the same machine.

---

## 3. MGP AWARDS

- THE MANX GRAND PRIX TROPHY donated by A B Crookall to the winner of the Senior race.
- THE JUNIOR MANX GRAND PRIX TROPHY donated in memory of Douglas Pirie to the winner of the Junior race.
- THE LIGHTWEIGHT MANX GRAND PRIX TROPHY donated by Motor Cycle to the winner of the SuperTwin race.
- THE ULTRA LIGHTWEIGHT MANX GRAND PRIX TROPHY donated in memory of Albert Moule to the winner of the Lightweight race.
- THE AITCHESON TROPHY to the winner of Class A of the Newcomers race.
- THE BRADDAN BRIDGE TROPHY to the winner of Class B of the Newcomers race.
- THE WAYNE HAMILTON TROPHY to the winner of Class C of the Newcomers race.
- THE LORD WAKEFIELD CUP to the rider making the best overall performance in the Junior and Senior races who is not a winner of either race
- THE LADY HILL ROSE BOWL to the rider who is a local resident making the best performance during the Senior race.
- THE YORK TROPHY to the rider who is a local resident making the best performance during the Junior race.
- THE RAY COWLE TROPHY to the rider in any Manx Grand Prix race (but excluding the Newcomers Race) who makes the best performance on a 4 stroke machine of British manufacture
- THE WALLACE CUP to the rider who is a local resident making the best performance during the Newcomers race.
- THE LESLEY ANNE TROPHY to the female rider making the best performance during the Manx Grand Prix races
- THE CROMIE McCANDLESS TROPHY to the rider who is an Irish resident making the best during the Manx Grand Prix races.
- THE NORRIE WHYTE TROPHY to the rider who is a Scottish resident making the best performance during the Manx Grand Prix races.
- THE SEYMOUR TROPHY to the rider who is a National of a European country outside the British Isles making the best performance during the Manx Grand Prix races.

- THE MARTIN SMITH TROPHY to the rider who is a newcomer making the best performance during the Senior race.
- THE ALAN HAMPTON TROPHY to the rider who is a newcomer making the best performance during the Junior race.
- THE DAVE CORLETT TROPHY to the rider who is a newcomer making the best performance during the SuperTwin race.
- THE PHILIP HAYHURST TROPHY to the rider who is a newcomer making the best performance during the Lightweight race.
- THE HOGG TROPHY to the rider who is a local resident making the fastest lap during the Manx Grand Prix.
- A MEDAL will be presented to the rider of the highest placed 125 cc machine in the Lightweight race.
- A MEDAL will be presented to the rider of the highest placed 250 cc machine in the Junior race.
- THE GJA BROWN CLUB TEAM TROPHY to the Club having the winning team in the Senior race.
- THE JW DAVIE CLUB TEAM TROPHY to the Club having the winning team in the Junior race.
- THE BILLS/HARDING CLUB TEAM TROPHY to the Club having the winning team in the SuperTwin race.
- THE CASTLE HILL CUP to the Club having the winning team in the Lightweight race.
- THE PADGETT TROPHY to the Club having the winning team in the Newcomers race.
- THE DICKIE DALE TROPHY to the rider making the fastest lap in the Senior race.
- THE G D HANSON TROPHY to the rider making the fastest lap in the Junior race.
- THE FREDDIE FRITH TROPHY to the rider making the fastest lap in the SuperTwin race.
- THE PAM CANNELL TROPHY to the rider making the fastest lap in the Lightweight race.
- THE DUNCAN MUIR AND VAL CONATY TROPHY to the rider making the fastest lap in Class A of the Newcomers Race
- THE JEFFERIES TROPHY to the rider making the fastest lap in Class B of the Newcomers race.
- THE SEAN JACKSON AWARD to the rider making the fastest lap in Class C of the Newcomers race.

**PLEASE NOTE: The above MGP awards (except medals for the highest placed 125cc in the Lightweight and 250cc in the Junior races) will remain in the custody of the Club after the presentation.**

*Replicas will be awarded to the 1st, 2nd & 3rd in all classes. Subsequent replicas will be awarded as follows:-*

- In the Newcomers, SuperTwin, Lightweight, Junior and Senior races to those riders who finish within 1/10ths of the time taken by the respective winners or class winners;
- Club teams in each case shall consist of 3 members of a bona fide club affiliated to the ACU, SACU, MCUI or another national federation nominated by or on behalf of such club, on the form obtainable from the Race Office. The completed form should be lodged at the Race Office no later than 12 noon on the day preceding the race day with an entry fee of £15.00. Any application for changes must be lodged with the Race Office no later than 12 noon on the day preceding the race. In the case of a postponement of a race to another day, one or more riders may be substituted not later than 1700 hours on the day preceding the day to which the race is postponed. The winning club team will be decided on an aggregate basis. A club may enter more than one team but no rider shall be nominated for more than one team in any race. See ACU National Sporting Code as to eligibility for Club membership.
- Each member of the winning team and the rider putting up the fastest lap in each of the races will receive an award. Medals will be presented to the winners of fastest lap trophies and other special awards. Finishers' medals will be awarded to riders who complete any race in compliance with the regulations but fail to qualify for any of the premier awards or replicas.

PLEASE NOTE: It is a condition of receiving any award that the winner/s of the award shall attend to receive the award unless excused by the Club for a good reason.

## **AWARD PRESENTATION**

Details of the date and venue will be included in Final Instructions.

## **APPENDIX C - APPLICABLE TO CLASSIC TT MACHINES ONLY**

### **I. MACHINE ELIGIBILITY**

- The organisers retain the ability to accept an entry for a machine that is not compliant with these regulations if in their view it will enhance the spectacle of the racing without giving a competitor an unfair advantage. Such requests must be made in writing prior to the closing date for entries and will be accepted or rejected on a case by case basis.

#### ***I.1 Classic TT 500cc, 350cc, 250cc and FORMULA CLASSIC ELIGIBILITY***

##### ***The 500cc Classic TT Race***

- 301cc–500cc Machines
- 

##### ***The 350cc Classic TT Race***

- 300cc - 350cc Machines
- 

##### ***The 250cc Classic TT Race***

- 175cc - 250cc Machines
- 

##### ***The Formula Classic TT Race***

- Up to 850cc Machines Pre-31/12/1974
- 

#### ***The Following is applicable to the 500cc, 350cc and 250cc Classic Races***

- The 500cc, 350cc and 250cc Classic TT Races cater primarily for thoroughbred Grand Prix racing motorcycles constructed during:
    - (i) The period 01/01/1945 – 31/12/1972 inclusive, for all 4 strokes up to 500cc;
    - (ii) The period 01/01/1945 – 31/12/1967 inclusive, for all 2 strokes (with the addition of Greeves Oulton and Bultaco TSS built before 31/12/1968) for the specific purpose of participation in competition during that era.
- 

#### ***I.2 FORMULA 1 AND FORMULA 2 CLASSIC TT ELIGIBILITY***

##### ***The Formula 1 Classic TT Race***

- Up to 1300cc, air-cooled 4-stroke Machines Pre- 31/12/1986
  - Up to 1300cc, liquid cooled 4-stroke Machines Pre- 31/12/1986
  - Up to 750cc 4-stroke, 4 cylinder Machines Pre 31/12/1992
  - Up to 1000cc 4-stroke, 2 and 3 cylinder Machines and Norton rotary-engined machines Pre- 31/12/1992
  - 351cc - 750cc 2 stroke Machines Pre- 31/12/1992
- 

##### ***The Formula 2 Classic TT Race***

- Up to 750cc 4 stroke, 2 cylinder Machines Pre- 31/12/1986
- Up to 600cc 4 stroke, 4 cylinder Machines Pre- 31/12/1986
- 126cc -350cc 2 Stroke Machines Pre- 31/12/1992



### **1.3 GENERAL CONSIDERATIONS**

- In formulating these Classic Regulations, the organisers have endeavored to produce races for machines built using components available in the eligibility periods. When looking at entries, consideration will be given to the period appearance of the machine as well as adherence to the letter of these regulations.
- Machines may also incorporate components of a type manufactured before the 31st December cut-off date or manufactured after that date without substantial alteration. Competitors are expected to present machines with visible components (e.g. wheels) generally similar to a type available in the period.
- All components fitted must be of a type available and fitted to machines of the relevant classes within the relevant classic period, defined below. This includes all major components such as frame, forks, wheels etc. No modifications (other than those specifically authorised in these regulations) will be permitted unless used during the period.
- Where components are of later manufacture, they must resemble the original period components.
- The onus is on the rider or entrant to prove eligibility if required.
- Entries will not be accepted without a specification sheet for each machine entered and with photographs, with and without fairing, if applicable. Riders who are in any doubt about eligible components or modifications are invited to contact the Chief Eligibility Officer for a ruling.

### **1.4 OIL CONTAINMENT**

- Oil Containment is compulsory for all 4 stroke machines (i.e. faired and un-faired). The oil containment must be of rigid construction fastened securely to the machine and have a capacity of at least half of the total oil (and coolant) capacity in the event of an engine failure. The oil containment for un-faired machines must be at least 50mm deep and at the front must extend upwards to at least 50mm below the base of the cylinder except in the case of horizontal cylinder machines (e.g. Aermacchi) which will be subject to the agreement of the Chief Technical Officer whose decision is final.

### **1.5 SEAT, TANK AND FAIRING**

- Motorcycles must be presented in period condition. Seats, tanks and fairings (if fitted) must be of a style and type manufactured and used in the appropriate period. The motorcycle must have only one fuel tank which must not hold more than 24 litres.

*Rules 1.6 – 1.16 apply to 500cc, 350cc, 250cc and Formula Classic machines only (see later Rules 1.17 – 1.27 below for Formula 1 Classic and Formula 2 Classic)*

### **1.6 WHEELS**

- Must be of a wire-spoked construction and of 18" or 19" diameter. A maximum rim width of WM3 for Classic classes i.e. up to 500cc machines, and a maximum rim width of WM4 for Formula Classic machines. Cast wheels will not be permitted, except for the Arter Matchless and John Player Norton (original wheels should be crack tested before use)

### **1.7 TYRES**

- Owing to variations in weather conditions which can occur on the TT Course and in the interests of safety, only tyres having a moulded tread pattern will be permitted. No additional cutting of moulded tyres will be permitted. No slicks, cut or uncut, will be allowed. Metal valve caps (not extractor type) must be fitted. Valves must be of the short stub stem type.

#### **Note for Classic machines only:**

Maximum tyre width, as stated on the manufacturer's specification sheet, shall be 4.50" (114mm) for 500cc, 350cc and 250cc Classic machines and 5.50" for Formula Classic machines. Tyres must be fitted with inner tubes.

### **1.8 BRAKES**

#### **500cc, 350cc and 250cc Classic and Formula Classic machines only**

- May be drum or disc for 4 strokes and Formula Classic 2 strokes.
- Only drum brakes may be used for Classic 2 strokes.
- All disc brake components must be pre-31/12/1972 for 4 strokes (pre-31/12/1974 for Formula Classic).
- Floating discs and/or 4 piston calipers will not be permitted.

- Discs must be solid and may be drilled only parallel to the wheel spindles. An unmodified out-of-period AP front brake master cylinder; part no CP3179-2 (plastic reservoir) is eligible, as is the AP Racing variable ratio front brake master cylinder parts no CP 3125-2 or CP 3125-4. The Grimeca front master cylinder as used on the Ducati 750 in 1972 is also acceptable.
- Where a rider has a genuine reason for not being able to operate a conventional brake lever; a thumb operated brake lever will be permitted. Due to space constraints, this may mean that an out of period master cylinder will be required. The use of such a device must be stated on the eligibility form and will be subject to prior approval by the Chief Technical Official.

### **1.9 SWINGING ARM, SUSPENSION AND FRONT FORKS**

- Must be of a pattern, type and material manufactured and used in the period.

### **1.10 CARBURETORS**

- Free choice of carburetor; with the exception of the following that are not permitted:
  1. Power jet carburetors
  2. Flat-slide carburetors (except Gardner carburetors)
  3. Fuel injection

### **1.11 ENGINE AND GEARBOX**

- May be modified internally and/or fitted with components of modern manufacture. All engine and gearbox casings must be unmodified externally, except modifications carried out in the period, to permit the fitment of belt primary drives, or to permit the repositioning of controls. All primary drives (belt and chain) must be totally concealed from view. Multi-valve heads are not permitted, unless available and used in the era. Non-period components, e.g. engine castings, oil filter castings, cylinder barrels and expansion chambers will not be permitted. External oil pumps are not permitted.

### **1.12 CLUTCH**

- Any clutch can be used but slipper clutches are not permitted

### **1.13 FRAMES AND REPLICA FRAMES**

- The frame should be what was used for the machine in the period. Replica frames will be permitted provided they are dimensionally accurate copies of known period chassis. For chassis without known pedigree, entries must be supported by documentary evidence proving eligibility.

### **1.14 SOUND**

- The ACU has granted a waiver of the sound level permitted under Standing Regulations.

### **1.15 EXHAUSTS**

- Must comply with ACU Standing Regulations

### **1.16 IGNITION SYSTEM**

- There is no restriction on the type of ignition system used. If non-standard electronic units are used, components should be concealed where possible
- Rules 1.17 – 1.27 apply to Formula 1 Classic and Formula 2 Classic machines only

### **1.17 WHEELS**

- Free choice – as many machines of this era will have used magnesium alloy wheels which are subject to metal fatigue over time, in the interests of safety and availability, modern wheels that closely resemble what was used on the bike in the period may be used.
- Free choice of size.

### **1.18 TYRES**

- Owing to variations in weather conditions which can occur on the TT Course and in the interests of safety, only tyres having a moulded tread pattern will be permitted. No additional cutting of moulded tyres will be permitted. No slicks, cut or uncut, will be allowed. Metal valve caps (not extractor type) must be fitted. Valves must be of the short stub stem type.
- Free choice of size with no maximum tyre size requirement.

### **1.19 BRAKES**

- Free choice of brake caliper and master cylinder (including radial master cylinders but excluding radial calipers and carbon-fibre brakes)

### **1.20 SWINGING ARM, SUSPENSION AND FRONT FORKS**

- Suspension systems must resemble the type available and fitted in the relevant period for the machine (subject to the replacement of shock absorbers). Modifications can be made to allow a different size tyre to be used.

### **1.21 CARBURETORS AND AIRBOX**

- Free of restriction, but only if used within the period (i.e. if a machine did not have an airbox in the period, use of an airbox is not permitted; however, if a different make of carburetor was available in the period, it can be used)

### **1.22 ENGINE AND GEARBOX**

- All engine and gearbox casings must be unmodified externally\*, except modifications carried out in the period. May be modified internally and fitted with components of modern manufacture. Engines may be rebored up to the machine manufacturer's recommended maximum oversize but no more than 1.5mm+ if the actual capacity would then exceed the capacity class size.
- Engines must be complete and as originally produced by the manufacturer.

*\*Note: Formula 2 two-stroke Yamaha machines will be allowed to use the later 4DP cylinders, which externally look the same as the earlier 4DP00 version*

### **1.23 CLUTCH**

- Any clutch can be used. Slipper clutches are allowed.

### **1.24 FRAMES AND REPLICAS FRAMES**

- The frame should be what was used for the machine in the period. Replica frames will be permitted provided they are dimensionally accurate copies of known period chassis. For chassis without known pedigree, entries must be supported by documentary evidence proving eligibility.

### **1.25 SOUND**

- The ACU has granted a waiver of the sound level permitted under Standing Regulations.

### **1.26 EXHAUSTS**

- Must comply with ACU Standing Regulations

### **1.27 IGNITION SYSTEM**

- There is no restriction on the type of ignition system used.

---

## **2. ENTRY PROCEDURE & ENTRY FEES**

- Applications for Classic TT Race entries must be made online via the competitors' section of [www.iomtt.com](http://www.iomtt.com) no later than Friday 3rd May 2013. Any entries received after the closing date may not be accepted.
  - For each solo race reserve entries may be accepted in addition to the maximum of 90 confirmed entries. A maximum of 10 reserves will practice with the riders who have confirmed entries. Subject to qualification they will take the places (but not necessarily the starting numbers) of confirmed non-starters up to a maximum of 90 starters per race.
  - The promoters will cover the cost of entry fees (including Insurance), necessary to enter the 2013 Classic TT Races.
  - Applicants will be advised as soon as possible after the closing date of entries, whether or not they have been accepted.
  - The organisers reserve the right to refuse any entry.
-

### 3. RIDER STATUS AND RACE SUB CLASSES

- To ensure competitors of all abilities and experience and machinery of varying specifications can compete in the Classic TT Races in an environment that promotes equality and sportsmanship, a number of sub classes have been created for each Classic TT Race.
- The sub classes will be used to determine the awarding of replicas and other trophies, will be clearly identified in the official results and detailed in the official post race press reports.
- Furthermore each competitor will be allocated either a rider status of either GP Rider or Privateer Rider. The rider status will be allocated to the competitor by the organisers based on experience, previous results and any other relevant information.
- Qualification for individual riders will be based on the sub classes.

*The race sub classes will be as follows –*

#### **500cc Classic TT Race**

- Class 500GP1 301cc–500cc Single Cylinder and Push Rod Twin Cylinder Machines ridden by GP status Riders
  - Class 500P1 301cc–500cc Single Cylinder and Push Rod Twin Cylinder Machines ridden by Privateer status Riders
  - Class 500GP2 301cc–500cc Multiple Cylinder Machines ridden by GP status Riders
  - Class 500P2 301cc–500cc Multiple Cylinder Machines ridden by Privateer status Riders
- 

#### **350cc Classic TT Race**

- Class 350GP1 300cc - 350cc Single Cylinder Machines ridden by GP status Riders
  - Class 350P1 300cc - 350cc Single Cylinder Machines ridden by Privateer status Riders
  - Class 350GP2 300cc - 350cc Multiple Cylinder Machines ridden by GP status Riders
  - Class 350P2 300cc - 350cc Multiple Cylinder Machines ridden by Privateer status Riders
- 

#### **250cc Classic TT Race**

- Class 250GP1 175cc - 250cc Two Stroke Machines ridden by GP status Riders
  - Class 250P1 175cc - 250cc Two Stroke Machines ridden by Privateer status Riders
  - Class 250GP2 175cc - 250cc Four Stroke Machines ridden by GP status Riders
  - Class 250P2 175cc - 250cc Four Stroke Machines ridden by Privateer status Riders
- 

#### **Formula 1 TT Race**

- Class FIGP1 Pre 31/12/1986 air-cooled Machines ridden by GP status Riders
  - Class FIP1 Pre 31/12/1986 air-cooled Machines ridden by Privateer status Riders
  - Class FIGP2 Pre 31/12/1986 liquid Machines and pre 31/12/1992 Machines ridden by GP status Riders
  - Class FIP2 Pre 31/12/1986 liquid Machines and pre 31/12/1992 Machines ridden by Privateer status Riders
- 

#### **Formula Classic TT Race**

- Class FCGP1 Pre 31/12/1974 Machines ridden by GP status Riders
  - Class FCP1 Pre 31/12/1974 Machines ridden by Privateer status Riders
- 

#### **Formula 2 TT Race**

- Class F2GP1 Pre 31/12/1986 2 Stroke Machines ridden by GP status Riders
- Class F2P1 Pre 31/12/1986 2 Stroke Machines ridden by Privateer status Riders
- Class F2GP2 Pre 31/12/1992 2 Stroke Machines ridden by GP status Riders
- Class F2P2 Pre 31/12/1992 2 Stroke Machines ridden by Privateer status Riders
- Class F2GP3 Pre 31/12/1986 4 stroke, 2 cylinder Machines ridden by GP status Riders
- Class F2P3 Pre 31/12/1986 4 stroke, 2 cylinder Machines by Privateer status Riders
- Class F2GP4 Pre 31/12/1986 4 stroke, 4 cylinder Machines ridden by GP status Riders
- Class F2P4 Pre 31/12/1986 4 stroke, 4 cylinder Machines by Privateer status Riders

#### **4. AWARDS**

- THE 500cc CLASSIC TT RACETROPHY to the winner of the 500cc Classic TT Race
  - THE 350cc CLASSIC TT RACETROPHY to the winner of the 350cc Classic TT Race
  - THE 250cc CLASSIC TT RACETROPHY to the winner of the 250cc Classic TT Race
  - THE FORMULA 1 CLASSIC TT RACETROPHY to the winner of the Formula 1 Classic TT Race
  - THE FORMULA 2 CLASSIC TT RACETROPHY to the winner of the Formula 2 Classic TT Race
  - THE FORMULA CLASSIC TT RACETROPHY to the winner of the Formula Classic TT Race
  - SILVER REPLICAS will be awarded to the riders finishing within 105% of the winner's time (per sub class).
  - BRONZE REPLICAS will be awarded to the riders finishing within 110% of the winners time but not qualifying for a silver replica (per sub class).
  - FINISHERS MEDALS will be awarded to all other finishers.
- 
- 

#### **5. APPEARANCE FEES**

- Competitors competing in the Classic TT Races will be able to apply for appearance fees by providing information and justification to support the application to the promoters. Any payments to riders and teams will be negotiated directly between the promoters and authorised representatives of the individual riders and teams.

*The following items will provide the basis for the payment criteria –*

- Potential media coverage value (team and / or rider) achievable before, during and after event
- Demonstrable ability to promote the Classic TT and Isle of Man positively (team and / or rider)
- Previous performance at the TT and Classic MGP Races (team and / or rider)
- Previous recent performance at other high profile motorcycle international and domestic racing
- Size and scale of team (infrastructure etc) and presentation

The above list is neither exhaustive nor absolutely definable and should only be used as a guide.

---

---

## SUMMARY OF TIMES

### 1. SIGNING ON - PRE PRACTICE

- Friday 16 August 13:00 - 16:00 (All riders including Newcomers)
- Saturday 17 August 09:00 - 09:30 (Newcomers only) followed by course instruction)  
09:30 - 11:00 (All other riders)

### 2. BRIEFINGS

#### (a) Riders Briefings

- Friday 16 August 14:00 / 15:00 / 16:30
- Saturday 17 August 11:15 (All riders except Newcomers) / 12:00 (Newcomers Only)
- Monday 19 August 16:00

All Newcomers (any class) must arrive, sign on, take the Newcomers Course Instruction at 09:30 and attend the Newcomers (any class) briefing at 12:00 on Saturday 17 August or they may be excluded.

#### (b) Technical Briefings

- MGP riders at 13:15
- Classic TT riders at 14:00

#### (c) Newcomers' Pre-Race Briefing

- Pre-race briefings will be held for Classic TT Newcomers on Saturday 24 August and MGP Newcomers on Tuesday 27 August, both at 11:00 in the Pit Lane area if dry and Technical Inspections Bay if wet. These are compulsory.

#### (d) MGP Newcomers' Post Race Briefing

- A briefing will be held on Thursday 29 August at 11:00 (Newcomers A/B/C) in the Hailwood Centre. This is compulsory.

### 3. NEWCOMERS' COURSE INSTRUCTION

Departs at 09:30 on Saturday 17 August immediately after the Newcomers signing on session. This is compulsory and failure to attend may result in disqualification.

### 4. TECHNICAL INSPECTIONS

#### Pre Practice

Saturday 17 August	15:00 - 16:00	Newcomers incl Classic TT Newcomers
	15:30 - 19:10	Senior; Junior; SuperTwin (No Newcomers)
	16:30 - 20:10	Classic TT, Lightweight
Monday 19 August	16:00 - 19:00	Senior; Junior; SuperTwin (No Newcomers)
	17:15 - 20:00	Classic TT, Lightweight, All Newcomers
Tuesday 20 August	16:00 - 19:00	Classic TT, Lightweight, Newcomers B/C
	17:15 - 20:00	Senior Junior, SuperTwin, Newcomers A
Wednesday 21 August	16:00 - 19:00	Senior; Junior; SuperTwin, Newcomers A
	17:15 - 20:00	Classic TT, Lightweight, Newcomers B/C
Thursday 22 August	16:00 - 19:00	Classic TT, Lightweight, Newcomers B/C
	17:15 - 20:00	Senior; Junior; SuperTwin, Newcomers A
Friday 23 August	16:00 - 19:00	Classic TT, Lightweight, Newcomers B/C
	17:15 - 20:00	Senior; Junior; SuperTwin, Newcomers A
Saturday 24 August	11:00 - 14:00	Newcomer A/B/C, Senior; Junior; SuperTwin, Lightweight
Monday 26 August	11:00 - 14:00	Newcomer A/B/C, Senior; Junior; SuperTwin, Lightweight
Wednesday 28 August	10:00 - 11:30	Senior; SuperTwin, Lightweight

#### Pre Race

Nos 61 upwards	08:00 - 08:30
Nos 31 - 60	08:30 - 09:00
Nos 1 - 30	09:00 - 09:30

Any application for extension must be made during the times stated above

## SUMMARY OF TIMES

### 5. RACE TIMES

- 45 minutes before the start. Riders take possession of machines in holding area
- 15 minutes before the start. Riders marshalled to starting grid.
- 5 minutes before the start. Stand to. Clear grid.

#### **Saturday 24 August – Classic TT Race Day 1**

---

15:00	Race 1	The 500cc Classic TT Race	(4 laps)
-------	--------	---------------------------	----------

---

#### **Monday 26 August – Classic TT Race Day 2**

---

10:15	Race 2	The 350cc Classic TT Race	(4 laps)
-------	--------	---------------------------	----------

---

10:15	Race 3	The 250cc Classic TT Race	(4 laps)
-------	--------	---------------------------	----------

*(Races 2 and 3 will run concurrently)*

---

---

13:00	Race 4	The Formula 1 Classic TT Race	(4 laps)
-------	--------	-------------------------------	----------

---

13:00	Race 5	The Formula Classic TT Race	(4 laps)
-------	--------	-----------------------------	----------

---

13:00	Race 6	The Formula 2 Classic TT Race	(4 laps)
-------	--------	-------------------------------	----------

*(Races 4, 5 and 6 will run concurrently)*

---

#### **Wednesday 28 August – Manx Grand Prix Race Day 1**

---

10:15	Race MGP1	The Newcomers Race A	(4 laps)
-------	-----------	----------------------	----------

---

10:15	Race MGP2	The Newcomers Race B	(4 laps)
-------	-----------	----------------------	----------

---

10:15	Race MGP3	The Newcomers Race C	(4 laps)
-------	-----------	----------------------	----------

*(Races 1, 2 and 3 will run concurrently)*

---

---

13:15	Race MGP4	The Junior Manx Grand Prix Race	(4 laps)
-------	-----------	---------------------------------	----------

---

#### **Friday 30 August – Manx Grand Prix Race Day 2**

---

10:15	Race MGP5	The SuperTwin Manx Grand Prix Race	(4 laps)
-------	-----------	------------------------------------	----------

---

10:15	Race MGP6	Lightweight Manx Grand Prix Race	(4 laps)
-------	-----------	----------------------------------	----------

*(Races 5 and 6 will run concurrently)*

---

---

13:15	Race MGP7	The Senior Manx Grand Prix Race	(4 laps)
-------	-----------	---------------------------------	----------

---

